

HomeLink®

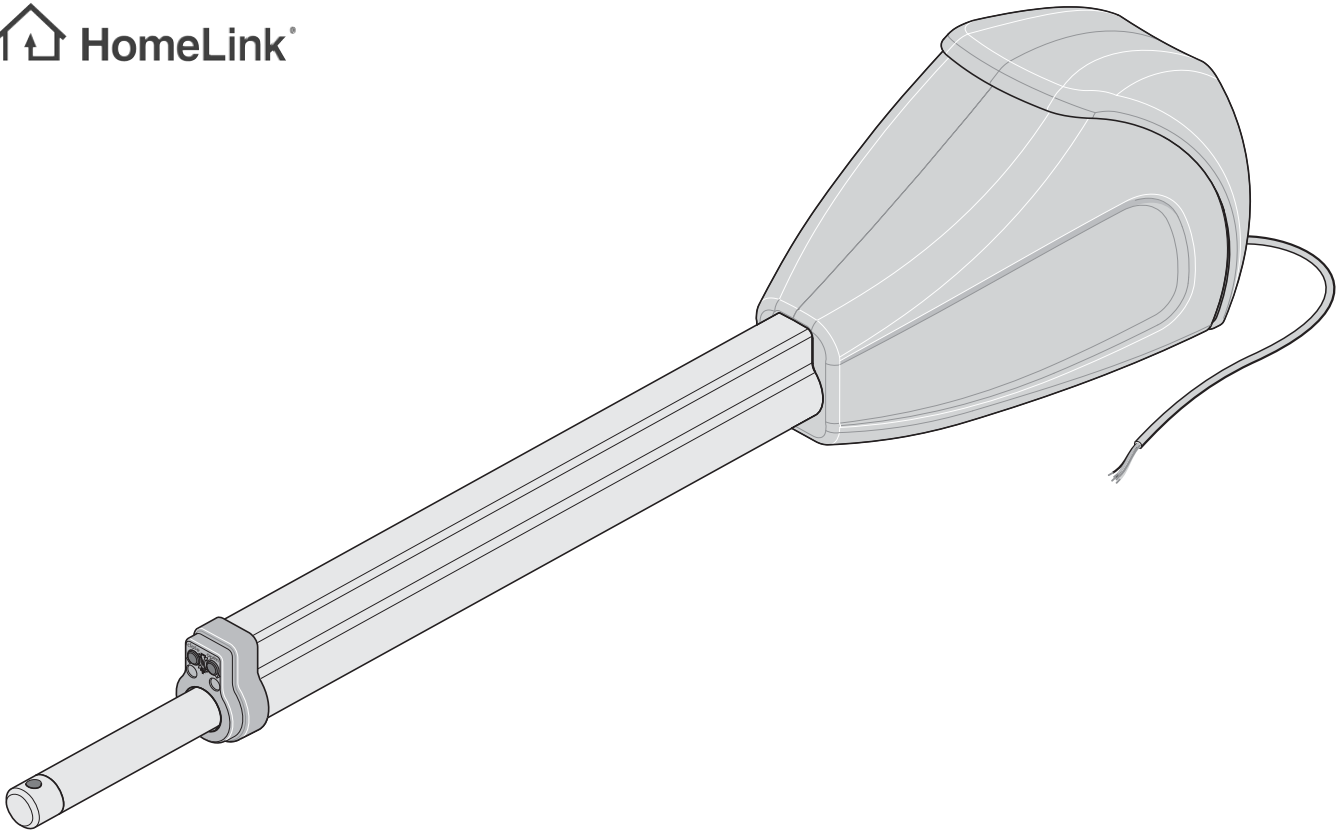

EN TRANSLATION OF THE ORIGINAL INSTALLATION AND OPERATING MANUAL

## Swing gate operator twist XL

serial number

# Table of contents

<b>General Information .....</b>	<b>3</b>	Connecting button (defined opening) .....	30
Symbols .....	3	Connecting button (Gate STOP) .....	30
Safety instructions .....	3	Connecting button (defined closing) .....	30
Intended use .....	3	Connecting EMERGENCY STOP .....	31
Improper use .....	3	Connecting 2-wire photo eye .....	31
Combined operation .....	3	Connecting 4-wire photo eye .....	31
Permitted gate leaf dimensions .....	4	Connecting external consumers .....	31
Technical data .....	4	Connecting potential-free relay contact .....	32
Dimensions .....	5	Connecting motor .....	32
Functional description .....	5	Attaching connecting cable set .....	32
<b>Installation preparations .....</b>	<b>7</b>	Main switch .....	32
Safety instructions .....	7	<b>Maintenance and care .....</b>	<b>33</b>
Tools required .....	7	Safety instructions .....	33
Personal protective equipment .....	7	Regular testing .....	33
Scope of delivery .....	7	<b>Miscellaneous .....</b>	<b>34</b>
<b>Installation .....</b>	<b>8</b>	Disassembly .....	34
Tips for installation .....	8	Disposal .....	34
Operator installation position .....	8	Warranty and customer service .....	34
A/B dimension table (reference values) .....	9	<b>Troubleshooting .....</b>	<b>35</b>
Fittings .....	10	Tips on troubleshooting .....	35
Installing fittings .....	10	<b>Connection diagram .....</b>	<b>37</b>
Installing the control unit .....	11	<b>DTA-1 control unit .....</b>	<b>38</b>
Connecting control unit to power mains (AC 230 V) .....	12	DIP switch settings .....	38
Connecting operator to control unit .....	14	TorMinal settings .....	38
Installation situation: "Opening gate outwards" .....	15	<b>Wiring diagram .....</b>	<b>39</b>
Adjust end positions .....	16		
Locking and unlocking the operator .....	17		
<b>Commissioning .....</b>	<b>18</b>		
Safety instructions .....	18		
Preparing continuous operation .....	18		
Adjusting the gate leaf length .....	18		
Enabling continuous operation .....	18		
Performing learning run .....	19		
Resetting the control unit .....	19		
Radio receiver .....	20		
Connecting external antenna .....	21		
<b>Operation/Use .....</b>	<b>22</b>		
Safety instructions .....	22		
Emergency release in case of power failure .....	22		
Normal mode .....	22		
Obstacle detection .....	22		
Summer-winter mode .....	22		
Opening and closing gate .....	22		
<b>Functions and connections .....</b>	<b>23</b>		
Safety instructions .....	23		
Jumper .....	23		
Button on control unit .....	23		
Potentiometer for gate leaf length .....	23		
Radio connector .....	23		
TorMinal interface .....	23		
Light-emitting diodes (LED) .....	24		
DIP switches .....	25		
Automatic closing function .....	26		
Fuses .....	28		
Transformer terminal .....	28		
DC 24 V electric lock .....	28		
Connecting warning light .....	29		
Connecting button .....	29		
Connecting key switch .....	30		

# General Information

## Symbols



**CAUTION SYMBOL:**  
Important safety instructions!

To ensure personal safety, it is important to observe all instructions. Save these instructions!



**IMPORTANT INFORMATION SYMBOL:**  
Information, useful advice!

**1 (1)** Refers to a respective picture in the introduction or main text.

## Safety instructions

### General

- These installation and operating manual must be read, understood and complied with by persons who install, use or perform maintenance on the operator.
- The manufacturer does not accept liability for damage or interruptions to business resulting from non-observance of the installation and operating manual.
- Always ensure compliance with accident prevention regulations and current standards in each respective country.
- All applicable Directives and standards must be observed and complied with for installation and operation, such as: EN 12453, EN 12604, EN 12605.
- Observe and comply with the "ASR A1.7 Technical Regulations for Workplaces" of the German Committee for Workplaces (ASTA), which is mandatory for the operator in Germany.
- Before doing any work on the gate or operator, disconnect it from the power supply and lock it to prevent reconnection.
- Electrical wiring must be firmly secured to prevent displacement.
- There is danger due to the crushing and shearing points presented by the mechanism and the closing edges of the gate.
- Never operate a damaged operator.
- After installation and commissioning, all users must be instructed in the function and operation of the swing gate operator.
- Only use OEM (Original Equipment Manufacturer) spare parts, accessories, and mounting material.

### Storage

- The operator must be stored in an enclosed, dry area at a room temperature between  $-20$  and  $+70^{\circ}\text{C}$ .
- The operator should be stored horizontally.

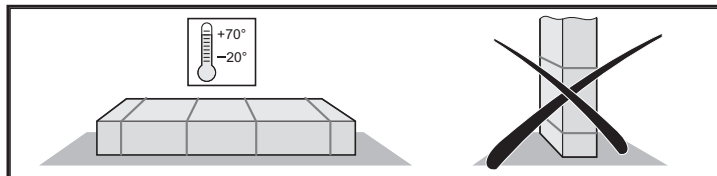

### ➤ Operation

- Do not allow children or persons who have not been instructed to operate the gate control unit.
- Open and close the gate only if there are no children, persons, animals or objects within its area of movement.
- Never put your hand near the gate when it is moving or near moving parts.
- Regularly check the safety and protection functions and repair faults immediately. See "Care and maintenance".
- Do not drive through the gate until it is fully open.
- Set the force tolerance as low as possible.

- For automatic closing, secure the main and auxiliary closing edges in accordance with the applicable directives and standards.
- Remove the key to prevent unauthorised use.

### Radio remote control

- If a risk of injury could occur due to radio malfunctions on the transmitter or radio receiver, use additional safety devices.
- Only use the radio remote control when the range of movement of the gate is visible and free of obstacles.
- Store the transmitter so that it is protected from unintended operation, e.g., by children or animals.
- Do not use the radio remote control in areas with sensitive radio communications or systems, e.g. airports or hospitals.
- When significant interference occurs due telecommunications equipment, contact the responsible Telecommunications Office which has radio interference measuring equipment (radio location).

### Type plate

- The type plate is inside the cover of the control unit.

## Intended use



### IMPORTANT INFORMATION!

**After installation of the operator, the person responsible for the installation must complete an EC declaration of conformity for the gate system in accordance with Machinery Directive 2006/42/EC and apply the CE mark and a type plate. This is also required for private installations and also if the operator is retrofitted to a manually operated gate. This documentation and the installation and operating manual are retained by the operator.**

- The operator is designed exclusively for opening and closing one- and two-leaf swing gate installations. Any other use does not constitute intended use.
- The manufacturer accepts no liability resulting from use other than intended use and the warranty expires. The user bears the sole responsibility for any risk involved.
- The operator must be in good technical condition, and it must be used for its intended purpose with awareness of the hazards. Observe the installation and operating manual.
- Only operate the twist XL with DTA-1 control unit.
- Only use the twist XL operator and DTA-1 control unit in private, non-industrial settings.
- Repair faults without delay.
- Only use operator on gates which comply with all valid standards and directives: e.g. EN 12453, EN 12604, and EN 12605.
- Uphold safety distances between the gate leaf and the environment in accordance with EN 12604.
- Only use stable and rigid gate leaves. Gate leaves must not bend or twist when opening and closing.
- Ensure there is little play in the hinges of the gate leaf.

## Improper use

- Opening or closing flaps, e.g. for access to roofs or similar.

## Combined operation

- 1x twist XL and 1x twist 350 mixed operation possible.
- 1x twist XL and 1x twist 200 E or 200 EL mixed operation only possible in connection with DTA-1 control unit and the "twist XS" conversion set (3248V000).

# General Information

## Permitted gate leaf dimensions

- Gate inclination: 0 %

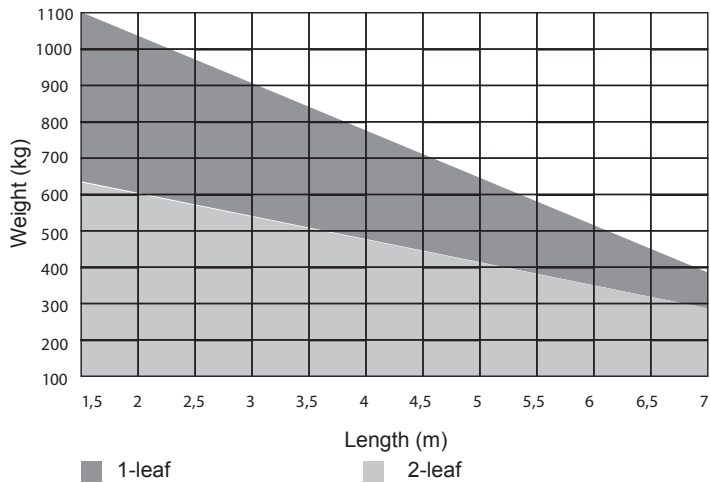

## Fill table

Height (m)	Fill (%)						
	1.5	2	3	4	5	6	7
5	100	100	70	40	20	-	-
4	100	100	90	50	30	20	-
3	100	100	100	60	40	30	20
2	100	100	100	100	60	40	30
1	100	100	100	100	100	90	60
Length (m)	1.5	2	3	4	5	6	7

Specifications valid for B dimensions 300 mm and A dimensions 140 mm; recorded values for gate panel thickness 50 mm and centre rotation point, related to the maximum given gate weight.

## With lift gates



### CAUTION!

Risk of injury from uncontrolled shutting in unlocked state with lifting gates which are not weight-balanced.

- Only use weight-balanced lifting gates.
- Only use lifting gates with special gate fittings: Gate fitting 7634

- Weight: max. 300 kg
- Length: max. 5 m
- Gate inclination: max. 10 %

## Technical data

	twist XL
Mains voltage	220–240V AC
Rated frequency	50/60 Hz
Storage locations in radio receiver	112
Operating time	S3 = 40%
Operating temperature	↓ -25 °C to ↓ +70 °C
Emission value according to operating environment	58 dBA
IP protection class control unit	IP65
IP protection class operator	IP44
IP-code	I
Max. feed speed	20 mm/s
Max. traction and pressure force per leaf	4500 N
Rated torque per leaf	1500 N
Maximum power consumption per leaf	245 W
Maximum current consumption per leaf	1.2 A
Rated power consumption per leaf	115 W
Rated current consumption per leaf	0.6 A
Power consumption on power-saving mode	4.5 W
Maximum gate weight per leaf *	1100 Kg
Maximum leaf length **	7 m
Gate inclination ***	10 %

\* With max. 1.5 m gate leaf width, 1-leaf system.

\*\* With max. 400 kg, 1-leaf system and max. 300 kg, 2-leaf system.

\*\*\* See

# General Information

## Dimensions

All dimensions are in millimetres.

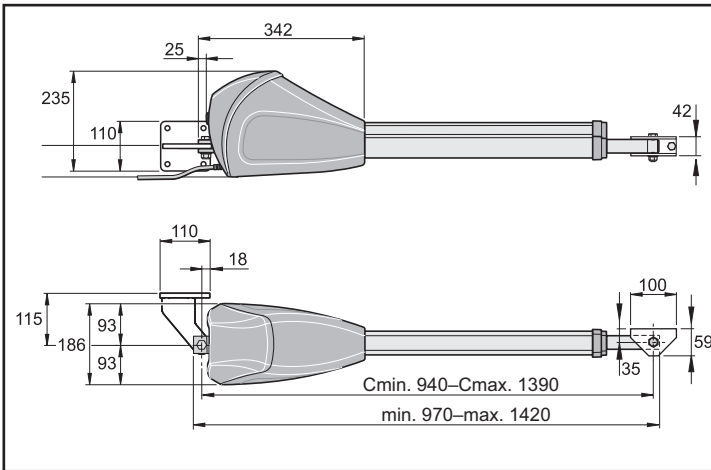
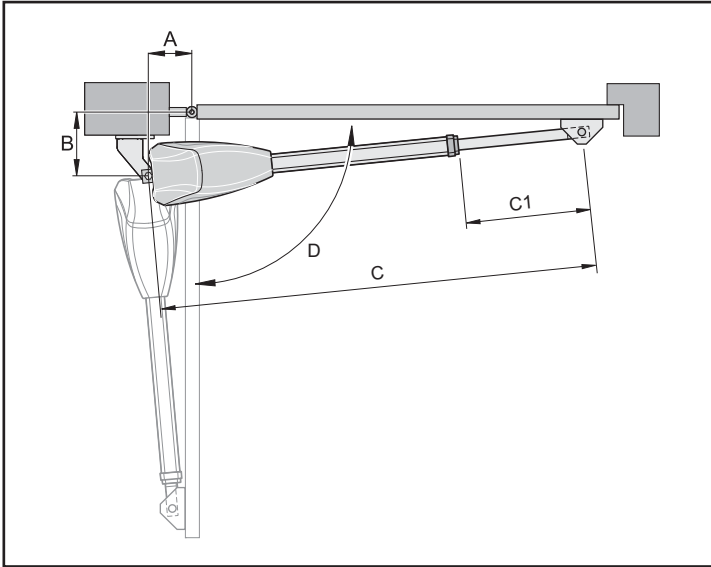

## Functional description



### IMPORTANT INFORMATION!

The "Gate OPEN" + "Gate CLOSE" end positions are set by internal limit switches in the operator and detected during operation.

The gate leaf is opened and closed by retracting and extending the gate operator. When the defined end positions are reached the operator is automatically switched off by the limit switch.

## Closing the gate



### IMPORTANT INFORMATION!

A mechanical stop at the "Gate OPEN" and "Gate CLOSE" end position is absolutely essential. An electric lock can be used as an additional lock.

The gate leaf does not require a lock, because the operator is self-locking. The gate cannot be pushed open manually without damaging the operator or the fittings.

## Wireless actuation

The operator can be operated with the supplied transmitter. The transmitter must be programmed for the radio receiver.

## Safety facilities

The control unit has an automatic force monitor. The necessary force must be programmed during a learning run.

When the operator requires a higher force than the one saved, the operator stops and reverses.

Various safety devices can be connected to the control unit, see chapter "Functions and connections".

Examples:

- Photo eye
- Safety contact strip with separate evaluation unit

## EN Remote control / Radio receiver

### EU Conformity Declaration

Messrs

SOMMER Antriebs- und Funktechnik GmbH  
Hans-Böckler-Straße 21-27  
D-73230 Kirchheim/Teck

declares herewith that the product designated below complies with the relevant fundamental requirements as per Article 3 of the R&TTE Directive 1999/5/EG, insofar as the product is used correctly, and that the following standards apply:

- Product: RF Remote Control for Doors & Gates
- Type: RM01-868, RM02-868-2, RM02-868-2-TIGA, RM03-868-4, RM04-868-2, RM08-868-2, RM01-434, RM02-434-2, RM03-434-4, RM04-434-2, RX04-RM02-868-2-wi6, RX04-RM02-868-2-TT, RX04-RM02-434-2, RX04-RM02-434-2-TT, RX01-RM02-868-2/4, RX01-RM02-434-4, TX02-868-2, TX02-868-2-UP, TX03-868-4, TX03-868-4-XP, TX35,-868-1/5, TX04-868- 10/30, TX08-868-4, TX02-434-2, TX03-434-4-XP, TX04-434-10 TX01-868, TX01-434, TX45-868-10, TX-45-434-10, RM10-868-1

The relevant guidelines and standards are:

- EN 60950-1
- EN 300 220-1
- EN 300 220 -2
- EN 301 489-1
- EN 301 489-3

Kirchheim/Teck, 07.01.2014  
Jochen Lude  
Responsible for documents

# General Information

## Declaration of Installation

for the installation of an incomplete machine in accordance with the Machinery Directive 2006/42/EC, Appendix II, Section 1 B

### SOMMER Antriebs- und Funktechnik GmbH

Hans-Böckler-Straße 21 - 27  
73230 Kirchheim/Teck  
Germany

hereby declares that the control unit

### twist XL

was designed, developed and manufactured in compliance with

- Machinery Directive 2006/42/EC
- Low Voltage Directive 2014/35/EU
- Directive on Electromagnetic Compatibility 2014/30/EU
- RoHS Directive 2011/65/EU.

The following norms were used:

- |                                  |  |
|----------------------------------|--|
| • EN ISO 13849-1, PL "C" Cat. 2  | Safety of machines – Safety-related parts of controls<br>– Part 1: General design guidelines   |
| • EN 60335-1/2, where applicable | Safety of electrical appliances/operators for gates  |
| • EN 61000-6-3                   | Electromagnetic compatibility (EMC) – interference   |
| • EN 61000-6-2                   | Electromagnetic compatibility (EMC) – interference resistance  |
| • EN 60335-2-103                 | General safety requirements for household and similar electrical appliances<br>– Part 2: Special requirements for operators for gates, doors and windows |

The following requirements of Annex 1 of the Machinery Directive 2006/42/EC are met:

1.1.2, 1.1.3, 1.1.5, 1.2.1, 1.2.2, 1.2.3, 1.2.4, 1.2.6, 1.3.2, 1.3.4, 1.3.7, 1.5.1, 1.5.4, 1.5.6, 1.5.14, 1.6.1, 1.6.2, 1.6.3, 1.7.1, 1.7.3, 1.7.4

The special technical documentation was prepared in accordance with Annex VII Part B and will be submitted to regulators electronically on request.

The incomplete machine is intended for installation in a gate system only to form a complete machine as defined by the Machinery Directive 2006/42/EC. The gate system may only be put into operation after it has been established that the complete system complies with the regulations of the above EC Directive.

The undersigned is responsible for compilation of the technical documents.

Kirchheim, 20-04-2016



i.V.

Jochen Lude  
Responsible for documents

# Installation preparations

## Safety instructions



**CAUTION!**  
**DANGER OF DESTRUCTION BY VOLTAGE PEAKS.**  
Voltage peaks, e.g. from welding machines, can destroy the control unit.

- Do not connect the control unit until all mounting tasks on the power supply have been concluded.



**CAUTION!**  
Before doing any work on the gate or operator, disconnect the control unit from the power supply and secure it to prevent reconnection.

- Lay cables in conduits approved for this purpose, e.g. for laying in underground installations.
- Only qualified electricians may connect the control unit to the power supply.
- Install in accordance with the installation and operating manual.
- Before installing the operator, take locking mechanisms which are not compatible with the operator (e.g. electric locks or bars) out of operation or disassemble them.
- Ensure that the operator is securely fastened to posts, pillars, and gate leaves to withstand large forces generated when opening and closing the gate.
- Flying sparks can damage the operator, e.g. when welding on posts or gate leaves. Cover or disassemble operator before welding.
- If a button is used for opening or closing, it must be installed out of the reach of children at a height of at least 1.6 m.
- Only use permissible fastening materials.

## Tools required

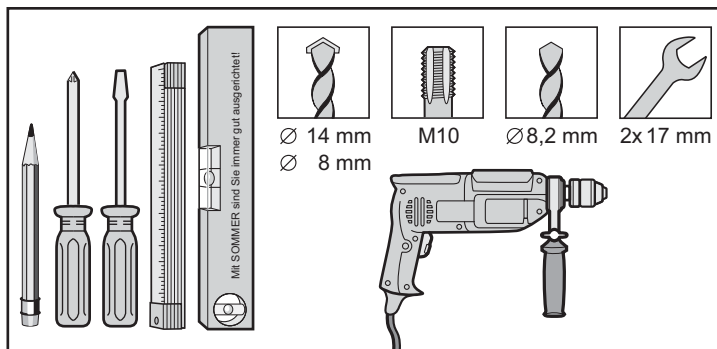

## Personal protective equipment

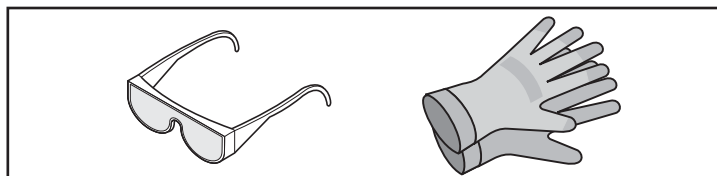

- Safety glasses (for drilling)
- Work gloves

## Scope of delivery

- Check the scope of delivery before installation to prevent unnecessary work and costs.
- The actual scope of supply may vary depending on the operator version.

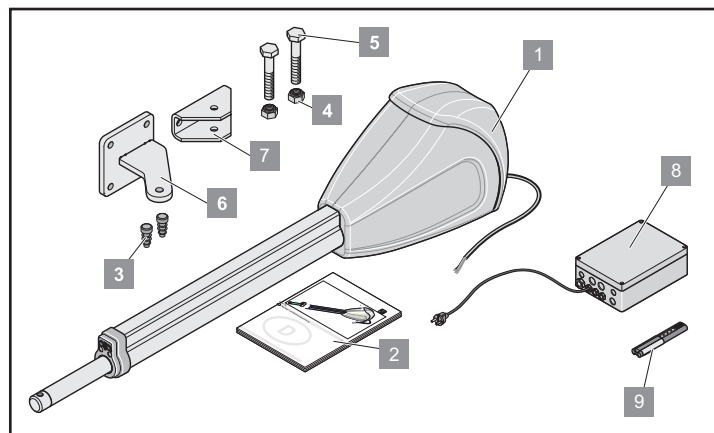

Operator set	1-leaf	2-leaf	
Weight (operator only)	12.5	2 x 12.5	kg
Package (L x W x H)	982 x 243 x 202		mm
1. Operator with cable	1 x	2 x	
2. Installation and operating manual	1 x	1 x	
3. Plug	2 x	4 x	
4. Locknut M12	2 x	4 x	
5. Hex bolt M12 x 70	2 x	4 x	
6. Fittings for post or pillar	1 x	2 x	
7. Fittings for gate leaf	1 x	2 x	

Controller set	1-leaf	2-leaf	
Weight (control unit only)	2.8	2.8	kg
Package (L x W x H)	120 x 245 x 285		mm
8. Control unit in housing (including radio receiver, transformer, and power plug)	1 x	1 x	
9. Hand-held transmitter, including battery	1 x	1 x	



# Installation

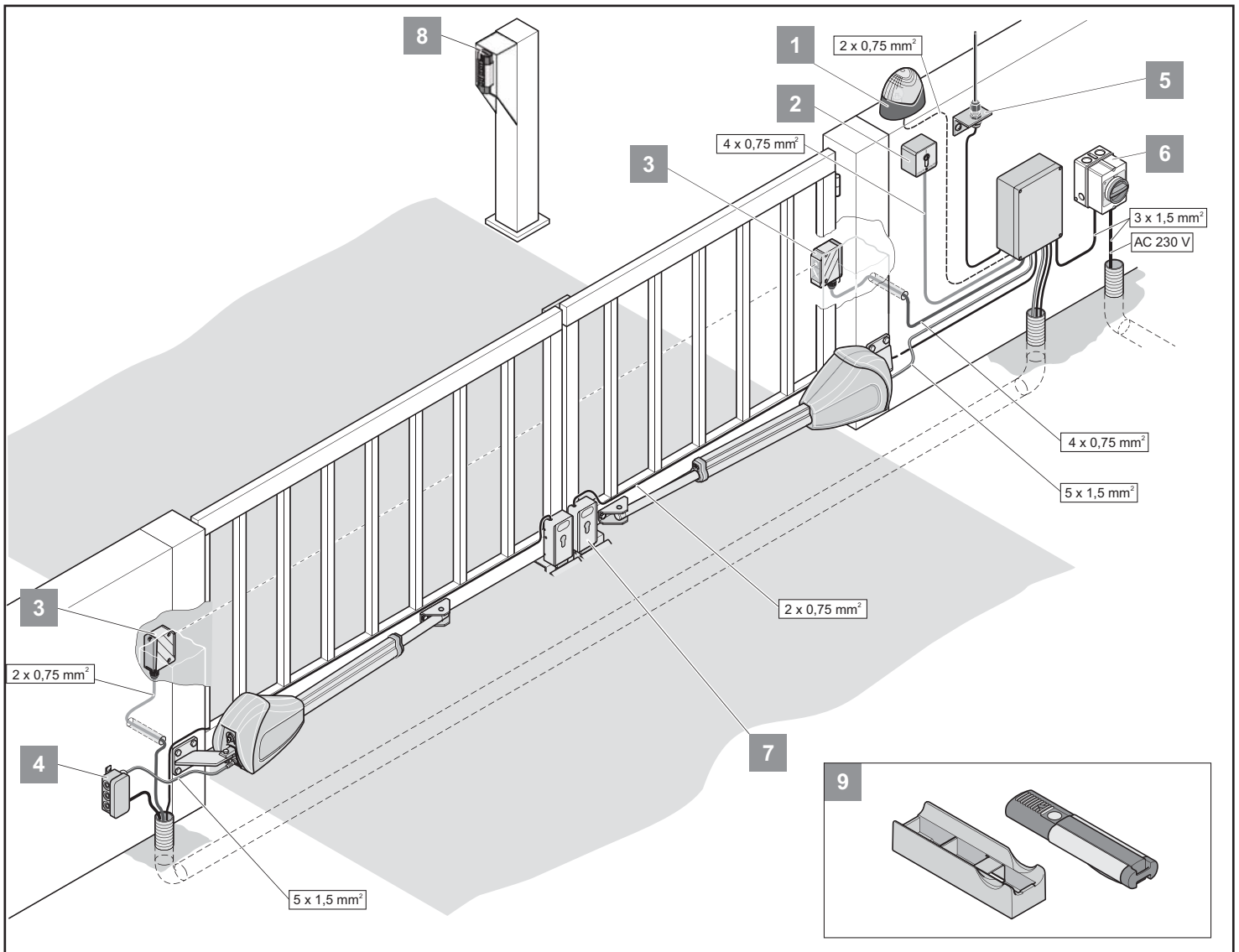

1.	Warning light DC 24 V / 24 W
2.	Key switch (1 or 2 contact)
3.	Photo eye
4.	Connecting cable set, 12 m
5.	External antenna (including cable)
6.	Main switch (lockable)
7.	DC 24 V electric lock/An electric lock can be connected to each gate leaf
8.	Telecodey
9.	Car/wall holder for transmitter

## Tips for installation

Define the installation location of the control unit together with the operator.

Install the housing so that it is hidden from unauthorised persons to prevent deliberate damage to the housing and control unit.

Attach threshold or stop bar to the gate:

- Gate leaf length longer than 2.5 m
- 2-leaf gate



### IMPORTANT INFORMATION!

Additional pulse transmitters are: transmitters, Telecodey, wireless indoor switches and key switches.  
For transmitters, Telecodey or the radio interior push-buttons, no connecting line must be installed for operation.

## Operator installation position

Install operator horizontally. Note installation position of motor; it must always point upright.

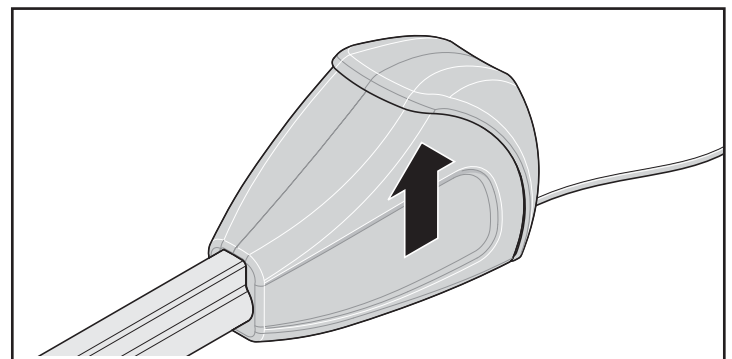



# Installation

## A/B dimension table (reference values)



### IMPORTANT INFORMATION!

Before mounting, define the A/B dimensions.  
Without these dimensions, the operator cannot be correctly installed and operated.

- Observe the different post and pillar dimensions.

**White fields:** Installation range only for horizontal gates

**Grey fields:** Installation range for lift and horizontal gates

**Attention:** Lift gates only with special fitting. For more information, see chapter "General Information" -> "With lift gates"

B	A		140	160	180	200	220	240	Max. gate leaf width Without electric lock				
	C	C1								D			
160	1243	360	1273	391	1314	431	1360	477	1385	503	1385	501	3.5 m
			<b>91°</b>	<b>93°</b>	<b>102°</b>	<b>110°</b>	<b>110°</b>	<b>103°</b>					
180	1265	382	1295	412	1335	452	1372	490	1384	501	1377	494	4.0 m
			<b>91°</b>	<b>95°</b>	<b>102°</b>	<b>108°</b>	<b>103°</b>	<b>96°</b>					
200	1287	404	1317	434	1354	471	1383	500	1376	493	1385	502	4.5 m
			<b>91°</b>	<b>95°</b>	<b>101°</b>	<b>103°</b>	<b>95°</b>	<b>93°</b>					
220	1306	423	1339	456	1373	490	1385	502	1385	502			5.0 m
			<b>90°</b>	<b>95°</b>	<b>100°</b>	<b>97°</b>	<b>92°</b>						
240	1328	446	1361	478	1390	507	1386	503					
			<b>90°</b>	<b>95°</b>	<b>98°</b>	<b>91°</b>							
260	1351	468	1381	498	1390	507							
			<b>90°</b>	<b>94°</b>	<b>91°</b>								
280	1374	491											
			<b>90°</b>										
300	1397	514											
			<b>90°</b>										



### IMPORTANT INFORMATION!

Select A/B dimensions so the desired opening angle (D) is reached. The specified opening angle is a reference value for the largest possible angle.



### IMPORTANT INFORMATION!

The reference values in the table have been calculated based on the following data:

- Wind speed 28.3 m/s
- Gate height 2.0 m
- Gate width 2.5 m
- Gate filling 35 %, uniformly distributed
- Without electric lock

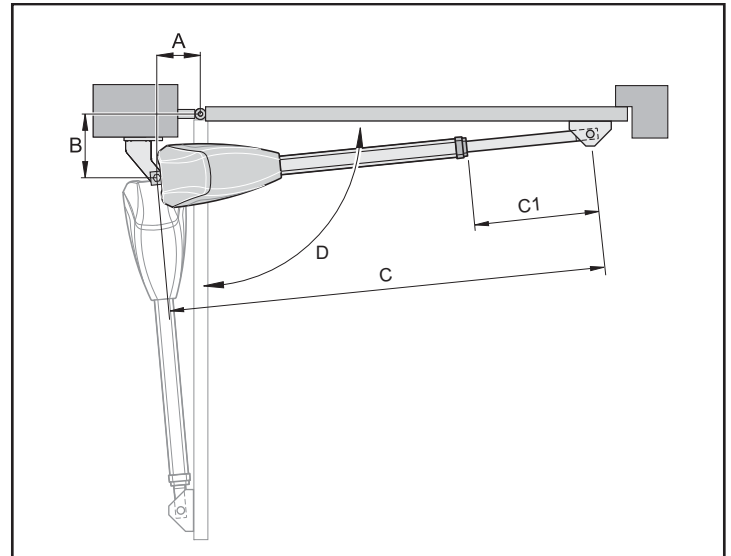

# Installation

## Fittings



### IMPORTANT INFORMATION!

The strength of the included fittings is designed for the operator. The warranty expires if other fittings are used.



### IMPORTANT INFORMATION!

The B dimensions must be at least 160 mm (see "A/B dimension table"). Compensation for smaller B dimensions with a space plate under the post fitting.

- Clearances between the gate leaf and post or gate leaf and operator must be maintained in accordance with the applicable standards.



### CAUTION!

Only use permissible fastening materials.

- Fasten fittings on stone or cement pillars with expansion dowels or adhesive-bonded anchors. The fastenings must not loosen during operation.
- Flying sparks can damage the operator, e.g. when welding on posts or gate leaves. Cover or disassemble operator before welding.



### CAUTION!

Welding and grinding residues accelerate corrosion of the fittings.

- After mounting the fittings, do not perform any more welding or grinding work.

## Steel posts

- Note the thickness of the post.
- Weld or bolt the fitting directly to steel posts.

## Brick or concrete pillars

- Uphold the distance of the fastening holes from the pillar edge. The distance depends on the type of expansion dowels or adhesive-bonded anchors. Observe the recommendations of the manufacturer.

## Post/pillar fitting

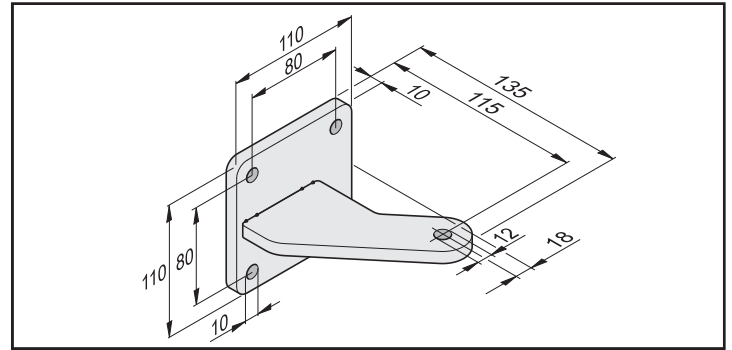

## Gate leaf fitting

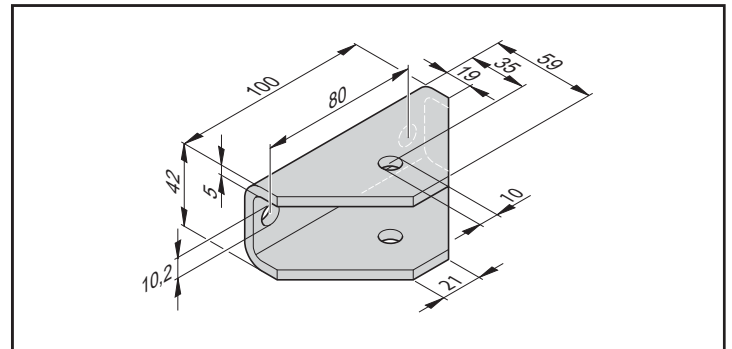

## Installing fittings

1. Close the gate by hand.
2. Compare the A/B dimensions with the A/B dimension table.
3. Fasten the post/pillar fitting temporarily (e.g. with a clamp).
4. Check installation situation and dimensions.
  - ⇒ Uphold distance to the floor: at least 50 mm.
5. Fasten post/pillar fitting.

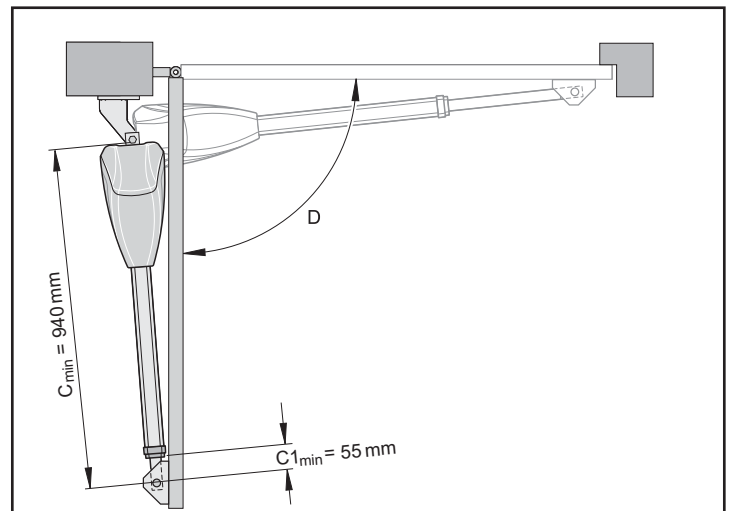

6. Manually move the gate to the "Gate OPEN" position. Note the maximum possible opening angle D from the A/B dimension table.
7. Hang the operator in the post fitting and secure it with a screw.
  - ⇒ The operator push rod is at maximum retraction as delivered.
8. Unscrew push rod, at least to  $C1_{min}$ .
9. Fix the gate leaf fitting to the push rod.

# Installation

10. Insert the screw from above.
11. Fasten the gate leaf fitting temporarily to the gate (e.g. with a clamp).
12. Unlock the operator, see chapter "Locking and unlocking the operator".
13. Close the gate by hand.

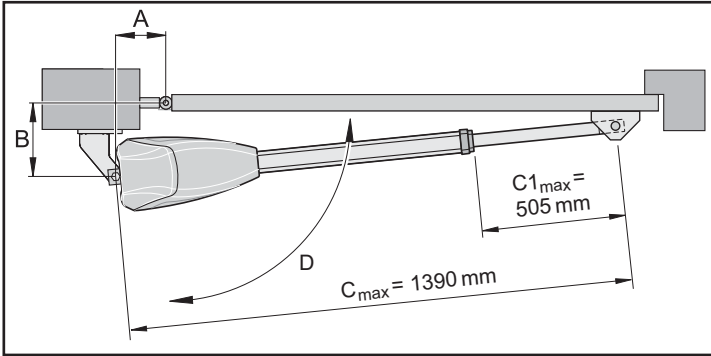

**i** **IMPORTANT INFORMATION!**  
The smaller the C1 dimension, the higher the stability.

14. Measure C1 dimensions and set between  $C1_{min}$  and  $C1_{max}$ .  
Do not exceed  $C1_{max}$ .
15. Check that the operator is horizontal in the positions:
  - "Gate OPEN"
  - "Gate CLOSE"
  - Opened 45°
16. Check the position of the gate leaf fittings.
17. Fix gate leaf fittings.
18. Screw in the nuts of the connecting screws (operator to fitting) only tight enough that the gate with the operator can still be turned easily.

## Installing the control unit



**CAUTION! DANGER OF DESTRUCTION BY MOISTURE**  
Penetration of moisture destroys the control unit.

- Only screw the housing on the intended fixing points.
- Install the housing vertically with the cable conduits facing downwards.
- Permitted cross-section of cable conduits: 1.5 mm<sup>2</sup> to 2.5 mm<sup>2</sup>.  
If cable cross-sections are smaller, a bushing must be attached on-site.
- Place the cover so it sits flush.

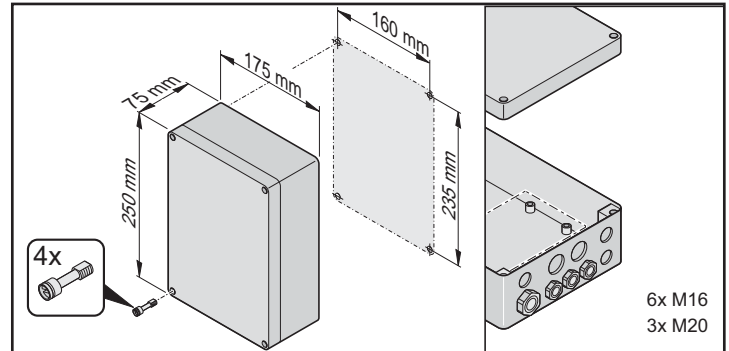

# Installation

## Connecting control unit to power mains (AC 230 V)



### CAUTION! DANGER OF ELECTROCUTION!

The control unit must be connected to the power mains by an electrician.

- Implement the mains connection according to EN 12453 (all-pole line disconnecter).
- Before doing any work on the gate or operator, disconnect it from the power supply and lock it to prevent reconnection.



### CAUTION!

The supplied mains cable is not approved for constant or outdoor operation.

- Only use this power cord for the mounting and commissioning of the operators.
- After completion of installation and commissioning: Replace power cord with a permanently laid line.



### IMPORTANT INFORMATION!

Approved wire cross sections for all terminals:  
0.5 mm<sup>2</sup>–2.5 mm<sup>2</sup>.



### IMPORTANT INFORMATION!

- Do not remove the sheath of the supply line until it is in the housing!
- Insert the sheath of the connecting line into the control unit housing.
- Remove the line sheaths as shown in the graphic.

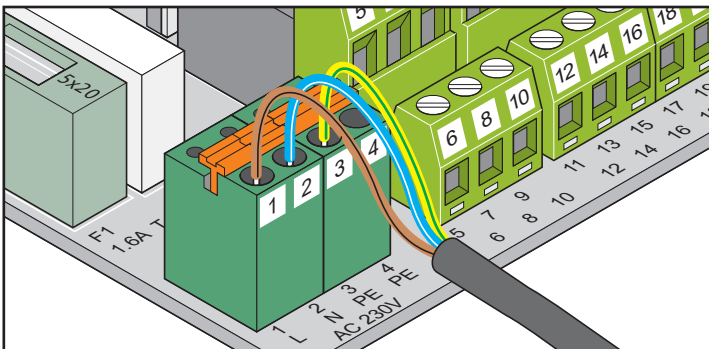
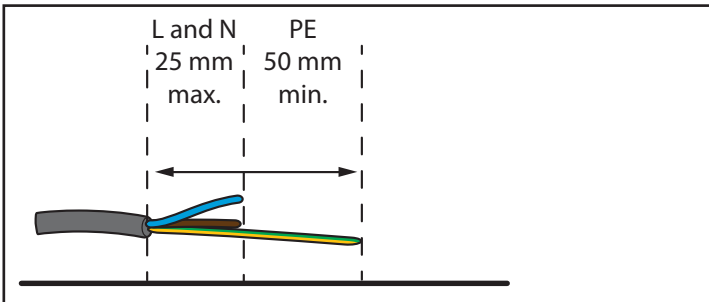

Terminal	Description	Description
1	L1	Outer conductor AC 230 V
2	N	Neutral wire
3 + 4	PE	Protective earthing conductor



### IMPORTANT INFORMATION!

Secure the line from being moved with cable binders!

# Installation

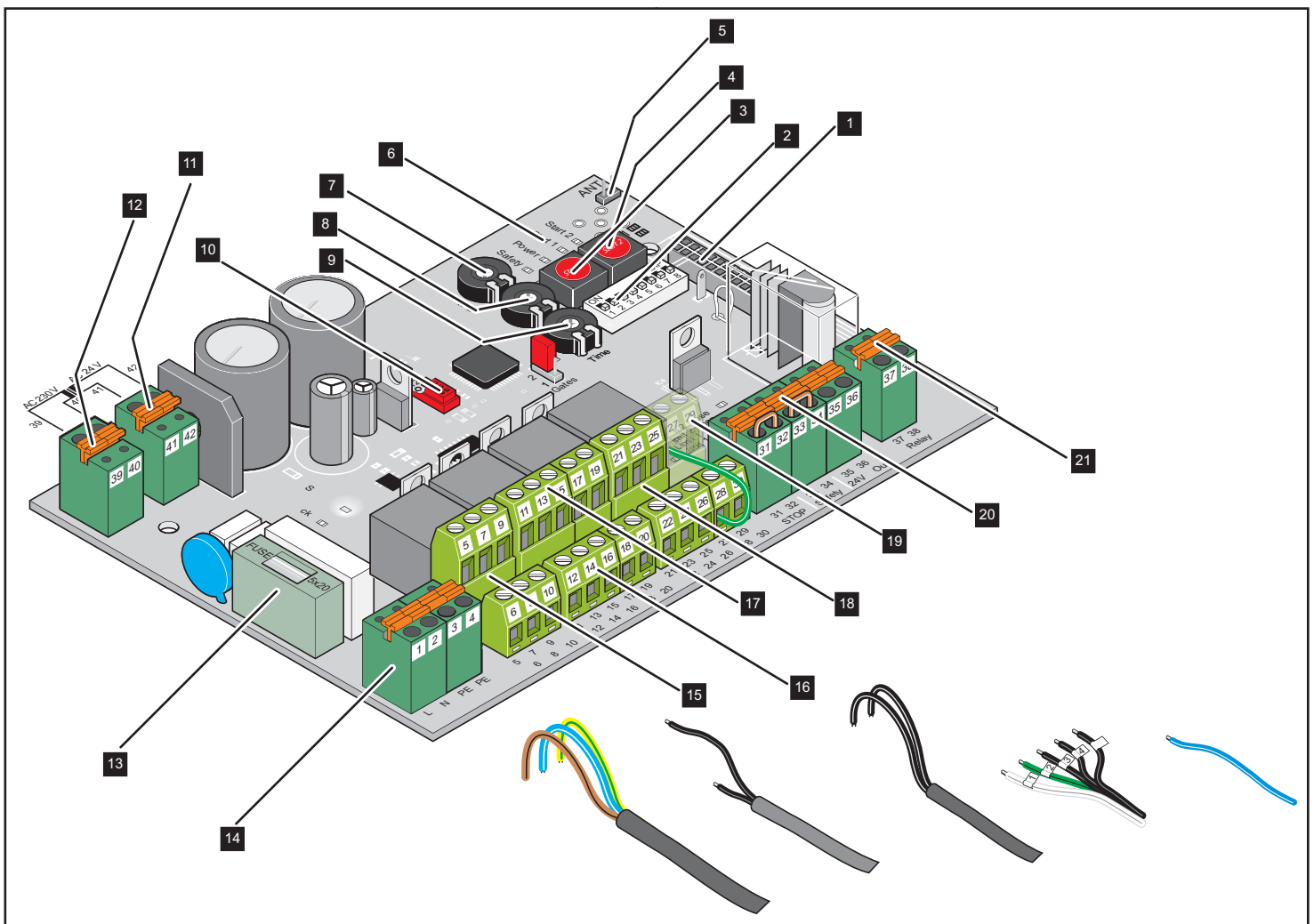

- |   |  |
|---|--|
| <ol style="list-style-type: none"> <li>1. Radio connector</li> <li>2. DIP switches</li> <li>3. Button (Start 1)</li> <li>4. Button (Start 2)</li> <li>5. Connection of the external antenna</li> <li>6. LEDs (Start 1, Start 2, Power, Safety)</li> <li>7. Potentiometer (Gate 2) for force tolerance of Motor 2 (M2)</li> <li>8. Potentiometer (Gate 1) for gate leaf length of Motor 1 (M1)</li> <li>9. Potentiometer (Time) for automatic closing function</li> <li>10. TorMinal interface</li> <li>11. Secondary transformer</li> </ol> | <ol style="list-style-type: none"> <li>12. Primary transformer</li> <li>13. Fuse 1.6 A, slow-acting</li> <li>14. Mains connection</li> <li>15. Connection for accessories</li> <li>16. Motor 1 (M1) connection</li> <li>17. Motor 2 (M2) connection</li> <li>18. Button connection</li> <li>19. LEDs (limit switch)</li> <li>20. Safety device connection</li> <li>21. Potential-free relay contact</li> </ol> |
|---|--|

# Installation

## Connecting operator to control unit

**CAUTION! DANGER OF ELECTROCUTION!**  
Before doing any work on the gate or operator, disconnect it from the power supply and lock it to prevent reconnection.

The operator is only correctly detected by the control unit after connection in a de-energised state.

**CAUTION!**  
Never connect the operator directly to the AC 230 V mains power.  
Risk of deadly electric shock!

**IMPORTANT INFORMATION!**  
Observe jumper setting for 1- and 2-leaf gate systems!

### 1-leaf gate

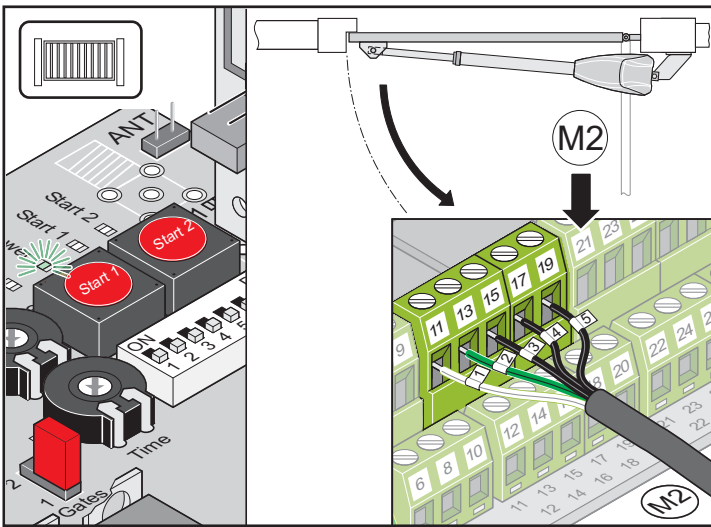

Terminal	Description	Description
11	1	Motor 2 (M2) connection
13	2	
15	3	Gate CLOSE limit switch
17	4	Gate OPEN limit switch
19	5	GND limit switch

### 2-leaf gate

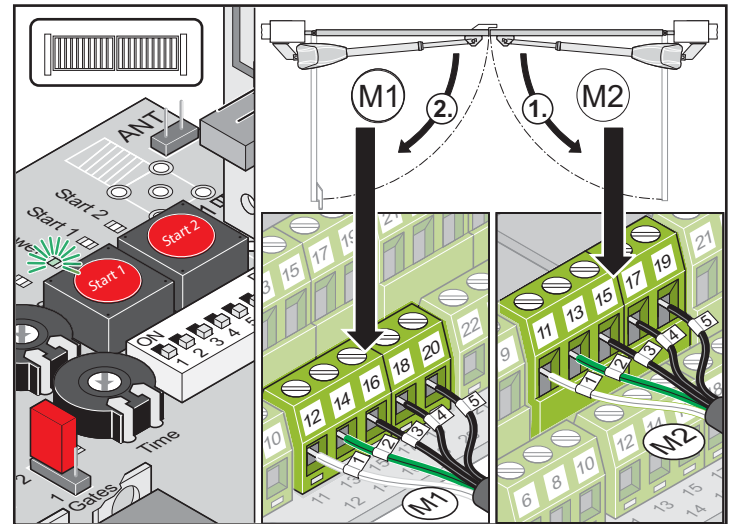

Terminal	Description	Description
12	1	Motor 1 (M1) connection Gate leaf with stop opens last.
14	2	
16	3	Gate CLOSE limit switch
18	4	Gate OPEN limit switch
20	5	GND gate limit switch
11	1	Motor 2 (M2) connection Active leaf opens first.
13	2	
15	3	Gate CLOSE limit switch
17	4	Gate OPEN limit switch
19	5	GND gate limit switch

1. Connect and set inactive leaf Motor 1 (M1).  
(Inactive leaf: gate leaf which opens second and closes first)
2. Connect and set active leaf motor 2 (M2) on control unit.  
(Active leaf: gate leaf which opens first and closes second)

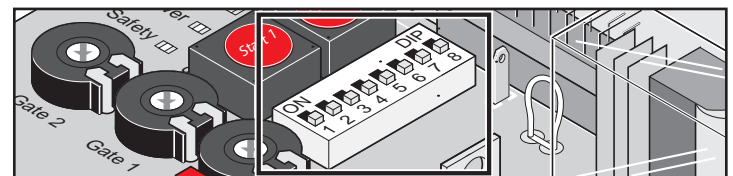

3. Set all DIP switches to "OFF".

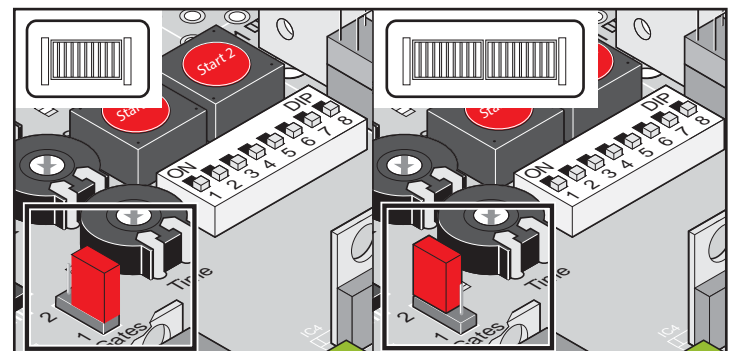

4. Set jumpers: Set 1- or 2-leaf gate.
5. Connect control unit to the power supply.
  - ⇒ "Power" LED on.
  - ⇒ The "Status" LED flashes.
  - ⇒ LEDs for the limit switches ("Limit 1 open" LED, "Limit 1 close" LED, "Limit 2 open" LED and "Limit 2 close" LED) on or off (depending on whether the push rod is extended or retracted).

# Installation

## Installation situation: "Opening gate outwards"

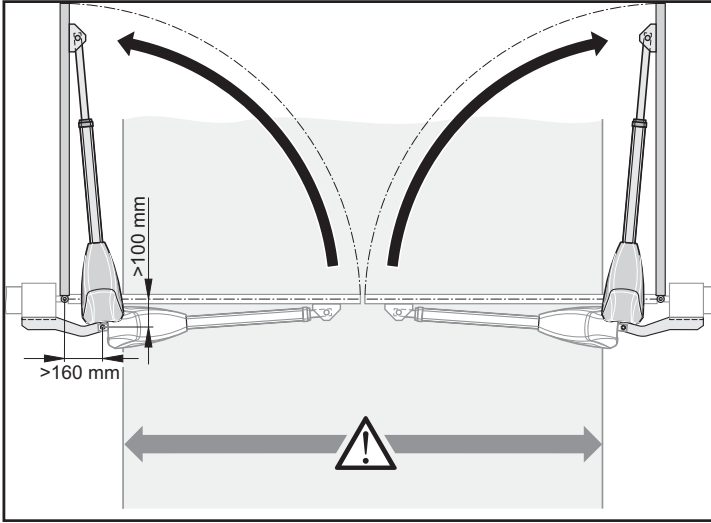

### CAUTION!

Depending on the installation situation, the operators protrude roughly 250 mm per side into the drive-through and reduce the drive-through width.

- Swapping A/B dimensions:  
A dimensions = B dimension in the A/B dimension table.  
B dimensions = A dimension in the A/B dimension table.
- Set post and pillar fittings according to A/B dimensions.



### IMPORTANT INFORMATION!

In the case of this "opening gate outwards" installation situation, the connection deviates from the standard connection.

Observe the following connection diagram!

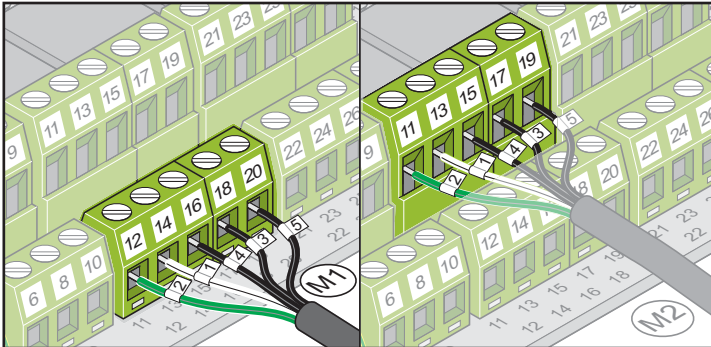

## 1-leaf gate

Terminal	Description	Description
11	2	Motor 2 (M2) connection
13	1	
15	4	End switch CLOSE
17	3	End switch OPEN
19	5	End switch GND

## 2-leaf gate

Terminal	Description	Description
12	2	Motor 1 (M1) connection Gate leaf with stop opens last.
14	1	
16	4	End switch OPEN
18	3	End switch CLOSE
20	5	End switch GND
11	2	Motor 2 (M2) connection Gate leaf with walk-through gate opens first.
13	1	
15	4	End switch OPEN
17	3	End switch CLOSE
19	5	End switch GND



# Installation

## Adjust end positions



### CAUTION! DANGER OF ELECTROCUTION!

Before doing any work on the gate or operator, disconnect it from the power supply and lock it to prevent reconnection.



### CAUTION!

Never connect the operator directly to the AC 230 V mains power.  
Risk of deadly electric shock!



### CAUTION!

Adjusting the limit switches with a battery-powered screwdriver or similar tool destroys the limit switches.

- Use recommended tools.



### CAUTION!

Connecting cables can jam when adjusting the limit switches in the protective tube.

- Insert and bundle the connecting cables after adjustment to prevent individual wires from pinching in the housing.



### IMPORTANT INFORMATION!

When no Motor 1 is connected, the "Limit 1 open" and "Limit 1 close" LEDs light constantly.



### IMPORTANT INFORMATION!

Setting the end positions achieves the following:

- The operator has maximum rigidity in the "Gate CLOSE" end position.
- The maximum possible path is fully used.
- Only one limit switch must be set to the "Gate CLOSE" end position.

## 1. Setting "Gate OPEN" end position

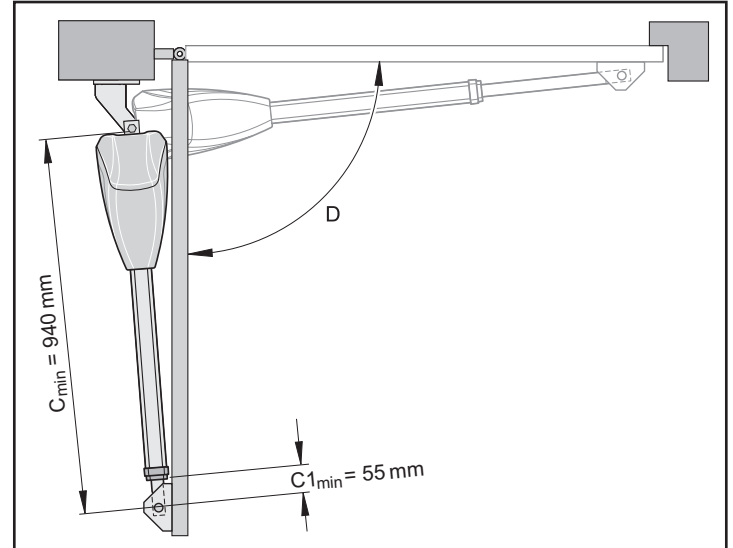

### IMPORTANT INFORMATION!

"Gate OPEN" end position preset to  $C1_{min}$ .

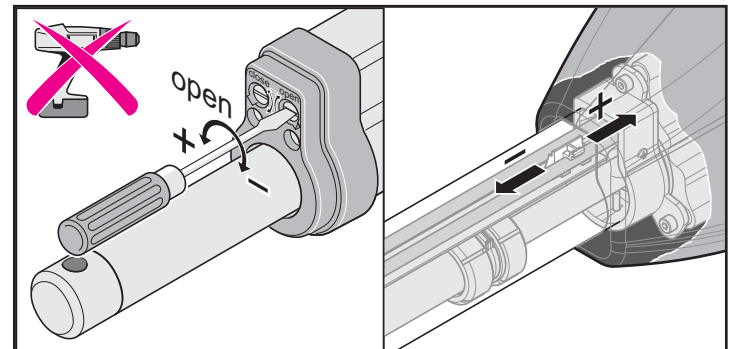

If necessary, readjust end position with a screwdriver.

- Extending travel length: Turn "open" setscrew in (+) direction.
- Reducing travel length: Turn "open" setscrew in (-) direction.



### IMPORTANT INFORMATION!

When the switching point of the limit switch is reached, the "Limit 1 open" or "Limit 2 open" LED is on.

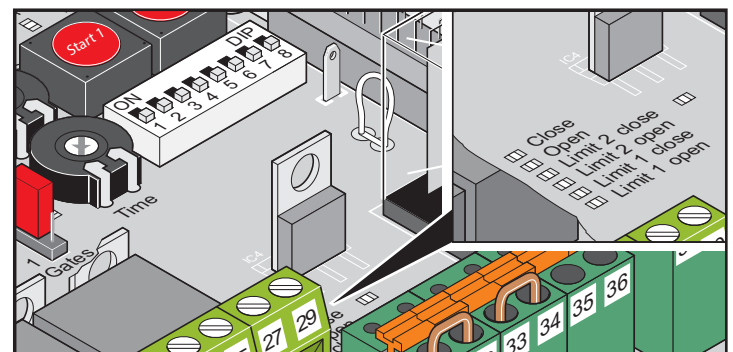

# Installation

## 2. Setting "Gate CLOSE" end position

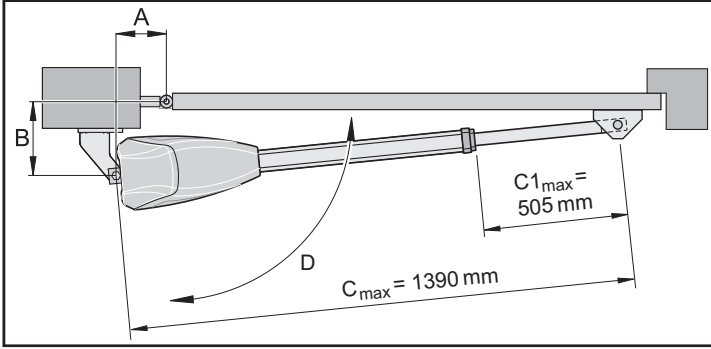

**i** **IMPORTANT INFORMATION!**  
 "Gate CLOSE" end position preset to  $C1_{max}$   
 Do not exceed maximum values:  $C1_{max}$  and  $C_{max}$ .

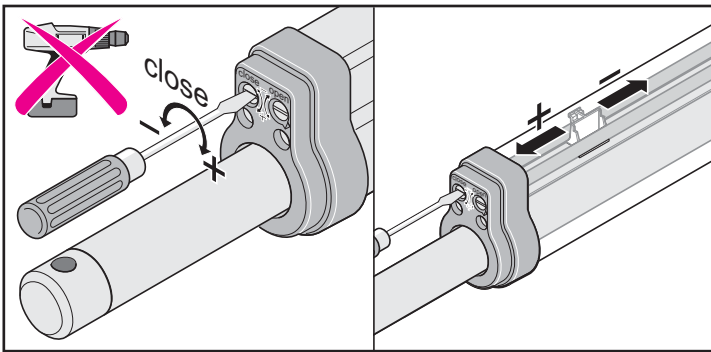

If necessary, readjust end position with a screwdriver.

- Extending travel length: Turn "close" setscrew in (+) direction.
- Reducing travel length: Turn "close" setscrew in (-) direction.

**i** **IMPORTANT INFORMATION!**  
 When the switching point of the limit switch is reached, the "Limit 1 close" or "Limit 2 close" LED lights.

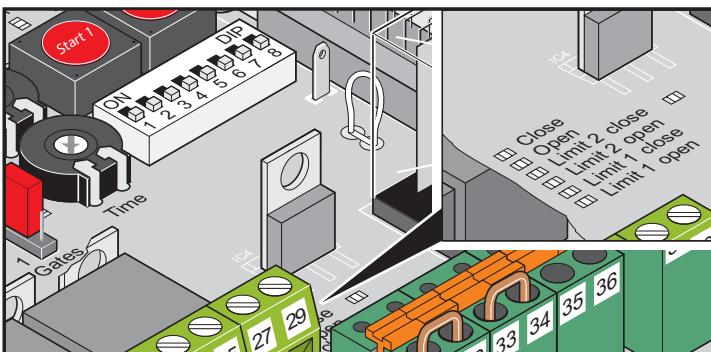

## Locking and unlocking the operator

**!** **CAUTION!**  
 Before doing any work on the gate or operator, disconnect it from the power supply and lock it to prevent reconnection.

**i** **IMPORTANT INFORMATION!**  
 The emergency release handle can only be adjusted with application of force and it engages noticeably.

In the event of a power failure, the gate can be moved by hand after unlocking.

### Unlocking operator

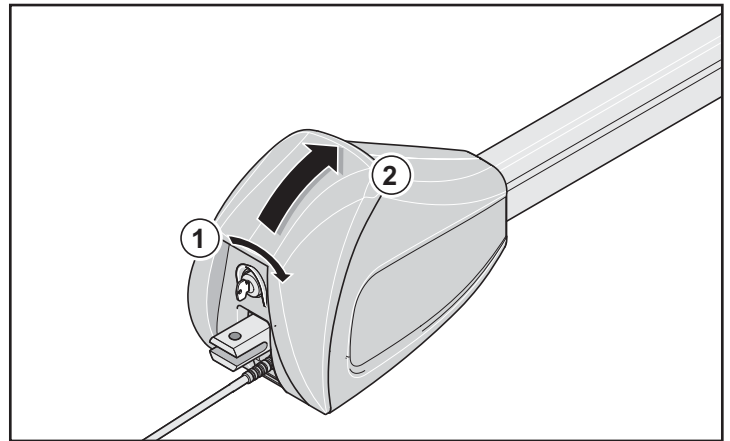

1. Insert the key (1) and turn it 90° clockwise.
2. Push emergency release handle (2) up to the stop.  
 ⇒ The motor is unlocked.  
 ⇒ The gate can now be moved by hand.

### Lock operator

1. Press emergency release handle (2) downwards and engage.

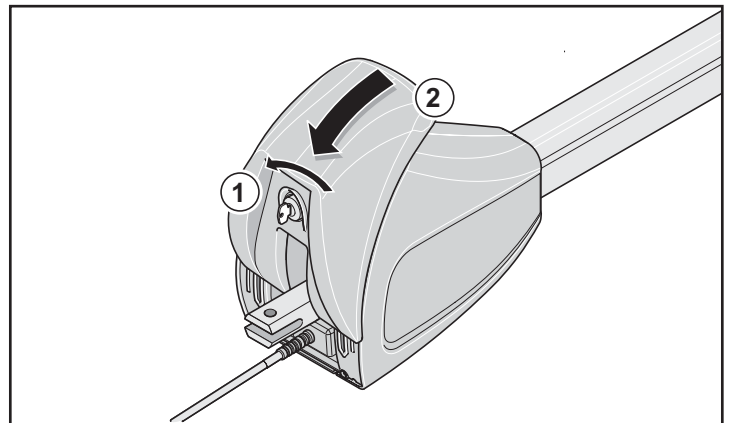

2. Turn key (1) 90° anti-clockwise and remove it.  
 ⇒ The motor is locked.  
 ⇒ The gate can now only be moved using the operator

# Commissioning

## Safety instructions

**CAUTION!**  
After installation of the operator, the person responsible for the installation must complete an EC declaration of conformity for the gate system in accordance with Machinery Directive 2006/42/EC and apply the CE mark and a type plate. This is also required for private installations and also if the operator is retrofitted to a manually operated gate. This documentation and the installation and operating manual are retained by the operator.

**CAUTION!**  
The adjustment of the force tolerance is safety-relevant and must be performed by qualified personnel with the utmost care. If the adjustment of the spring unit is excessively high, people or animals could be injured and objects damaged. Select a force tolerance that is as low as possible so that obstacles are detected quickly and safely.

**CAUTION!**  
Always perform learning run under supervision, because the operators traverse at full power. This is dangerous for persons, animals and object within the range of motion of the gates.

**CAUTION!**  
Before working on the gate or the operator always disconnect the control unit from the power supply and lock to prevent reactivation.

- "Status" LED and a connected warning light (accessory) flash during the learning run and as a visual warning at standstill.
- In the commissioning process the force required for opening and closing, the runtime and the closing delay are learned and saved by the control unit.

## Preparing continuous operation

**i IMPORTANT INFORMATION!**  
Do not use a metal object to set the DIP switches, because this may damage the DIP switches or the circuit board . The DIP switches can be set with a narrow, flat plastic object.

- Components for 1- or 2-leaf gate are connected and set, see chapter "Functions and connections".
  - Mains power is connected and voltage (AC 230 V) is present at control unit: "Power" LED on.
  - The fittings bolts are tightened, operators can be moved easily.
1. Lock operator and connect with padlock.
  2. Close the gate.

## Adjusting the gate leaf length

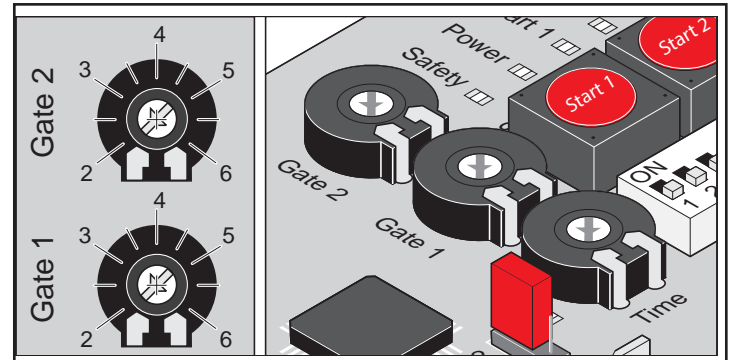

Setting	Gate leaf length	Description
2	approx. 2 m	Small gate <ul style="list-style-type: none"> <li>• High speed</li> <li>• Low force value</li> </ul>
3.5	approx. 3.5 m	Large gate <ul style="list-style-type: none"> <li>• Low speed</li> <li>• High force value</li> </ul>
3.5 to 7		Compensation of influences by A and B dimensions

## Changing gate leaf length after programming the operator

1. Reset the control unit.
2. Set the gate leaf length.
3. Perform learning run.

## Enabling continuous operation

- "Status" LED flashes until the force values, runtimes, and closing delays are learned and saved.

**i IMPORTANT INFORMATION!**  
**2-leaf gate close sequence.**

- **Motor 1 (M1) on the gate leaf with the stop closes first.**
  - **Motor 2 (M2) on the gate leaf with walk-through gate closes last.**
1. Check the setting of the limit switches.
  2. Open and close gate.
  3. If the operator switches off correctly at both end positions: Perform learning run.

# Commissioning

## Performing learning run



### CAUTION!

Always perform learning run under supervision, because the operators traverse at full power. This is dangerous for persons, animals and object within the range of motion of the gates.

1. Lock the operator, see chapter "Locking and unlocking the operator".

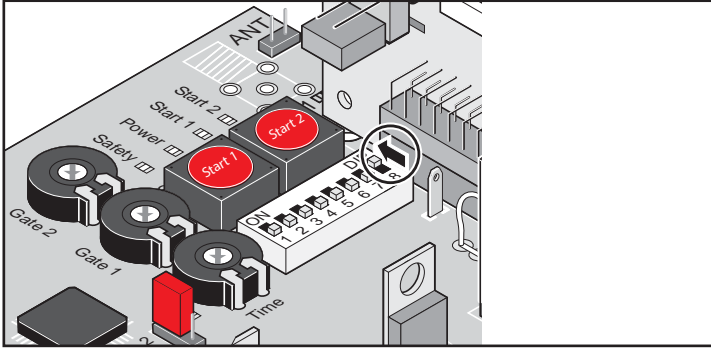

2. Set DIP switch 8 to ON.

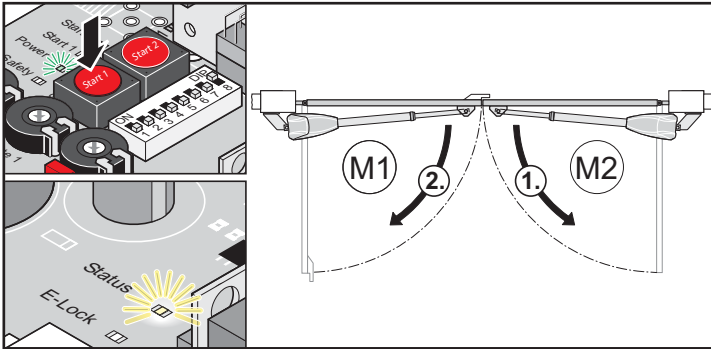

### IMPORTANT INFORMATION!

**Checking direction of running:** After the first command, the operator must traverse in the "Gate OPEN" direction. If the operator moves in direction "Gate CLOSE", reverse the operator connector cable on the control unit.

3. Press button (Start 1).
  - ⇒ Operators move into the "Gate OPEN" end position.
  - ⇒ "POWER" LED lights, "Status" LED flashes.

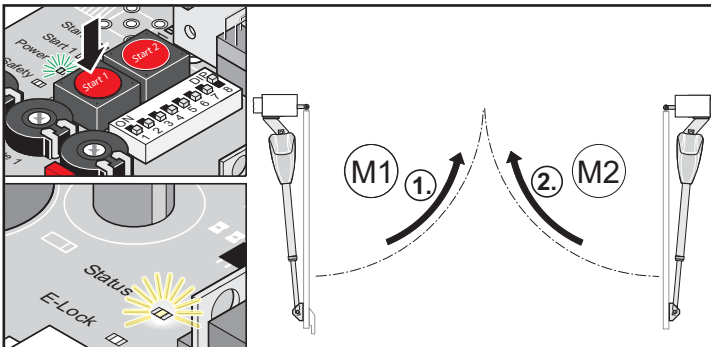

4. Press button (Start 1).
  - ⇒ Operators move into the "Gate CLOSE" end position.
  - ⇒ "POWER" LED lights, "Status" LED flashes.
5. Repeat steps 1 and 2.
  - ⇒ If all values are programmed: The "Status" LED goes out in both end positions.

6. Give the next command.
  - ⇒ The operators are started and stopped with soft running. Every time the gates are opened, the control unit monitors the force, runtime, and closing delay and adjusts them incrementally when the end position is reached.
7. Leave DIP switch 8 "ON".

## Detecting faulty learning runs

- Operators run without soft running.
  - "Status" LED flashes in both end positions.
1. Reset the control unit.
  2. Perform learning run.

## Resetting the control unit

The control unit reset deletes all programmed values (e.g. force values: force required by operator to open or close the gate, closing delay).

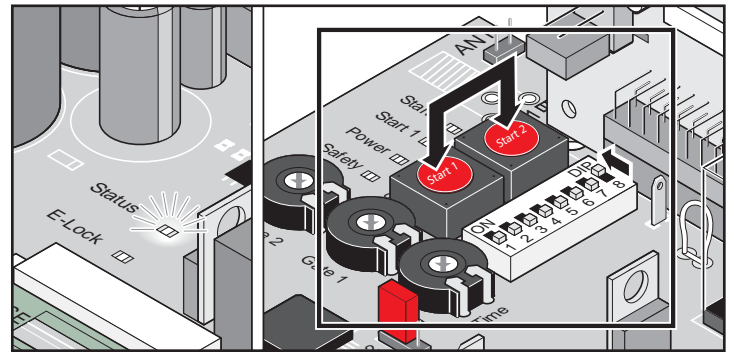

1. Press and hold the button (Start 1 + Start 2).
  - ⇒ The "Status" LED flashes.
  - ⇒ The "Status" LED goes out.
  - ⇒ All values deleted.
2. Release button.
  - ⇒ The "Status" LED flashes.
3. Perform a learning run, see chapter "Performing learning run".

# Commissioning

## Radio receiver

### Display and button explanation

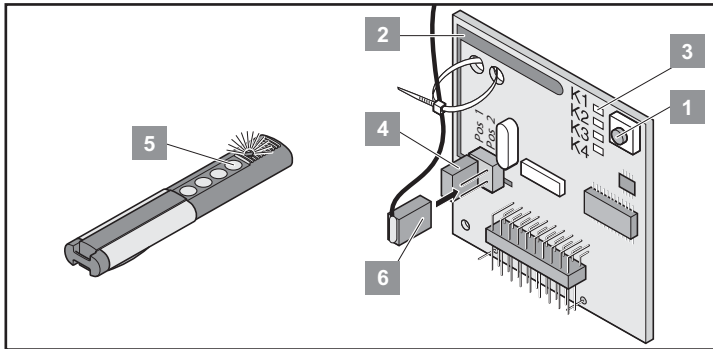

Button	Description
1	Teach-in button
2	internal antenna
3	LED: shows selected channel <ul style="list-style-type: none"><li>• K1 = radio channel 1 -&gt; same function as "Start 1" button *</li><li>• K2 = radio channel 2 -&gt; same function as "Start 2" button *</li><li>• ! K3 = channel 3 -&gt; no function</li><li>• ! K4 = radio channel 4 -&gt; no function</li></ul>
4	Connection of the external antenna (6)
6	External antenna

\* See chapter "Opening and closing gate".



#### IMPORTANT INFORMATION!

**Before programming transmitters: Delete the radio receiver memory.**

### Deleting the radio receiver memory

- If a hand-held transmitter is lost, all transmitters in the radio receiver must be deleted for security reasons!  
After that, reprogram all hand-held transmitters in the radio receiver.

1. Press and hold the Teach-in button (1).
  - ⇒ After 5 seconds, the LED flashes – after another 10 seconds, the LED is lights up steadily.
  - ⇒ After a total of 25 seconds, all LEDs light.
2. Release the Teach-in button (1).
  - ⇒ All LEDs go out – memory clearing process complete.

### Programming transmitter

#### 1-leaf gate

- Button 1 on radio channel 1.

#### 2-leaf gate

- Button 1 on radio channel 1 (both gate leaves open).
- Button 2 on radio channel 2 (only the active leaf opens).

1. Press the Teach-in button (1):
  - 1 x for channel 1; LED "K1" lights.
  - 2 x for channel 2; LED "K2" lights.
2. Press one of the transmitter buttons (5).
  - ⇒ The transmitter has sent the radio code to the radio receiver.
  - ⇒ When the radio code has been programmed: LED goes out.
3. Cancelling the teach-in mode: Press the Teach-in button (1) several times until no more LEDs are lit.



#### IMPORTANT INFORMATION!

**If no radio code is sent within 10 seconds, the radio receiver switches to normal operation.**

### Control

1. Press button 2.
  - ⇒ Only the gate leaf with walk-through gate opens.
2. Press button 1.
  - ⇒ Both gate leaves open.
3. Programming additional transmitters: Repeat "Programming transmitter".
  - The radio receiver can save a maximum of 112 different radio codes (transmitter buttons).
  - If a user moves a mutually used gate system and also takes the transmitter, all radio codes of the transmitter must be deleted from the radio receiver.

### Deleting radio code

1. Press Teach-in button (1) and keep it pressed for 5 seconds.
  - ⇒ LED "K1" or "K2" flashes.
2. Release the Teach-in button (1).
  - ⇒ The radio receiver is in Deletion mode.
3. Press the transmitter button of the radio code.
  - ⇒ LED goes off – wipe procedure complete.

### Deleting all radio codes of a channel

1. Press Teach-in button (1) and keep it pressed for 5 seconds.
  - 1x for channel 1
  - 2x channel 2
  - ⇒ The channel LED flashes.
2. Keep the Teach-in button (1) pressed for another 10 seconds.
  - ⇒ The channel LED lights up.
3. Release Teach-in button (1) – the deletion procedure is ended.

### Troubleshooting

#### All LEDs flashing

- All 112 storage locations of the radio receiver are occupied.  
If additional transmitters are to be programmed, delete radio codes from the radio receiver.

#### LED on

- Learn mode: radio receiver is waiting for a radio code from a hand-held transmitter.
- radio receiver is receiving a radio code from a hand-held transmitter.

# Commissioning

## Connecting external antenna

- Attach a strain relief on the antenna cable to prevent mechanical stresses on the radio receiver.
- If the range of the internal antenna is insufficient, connect external antennas.
- Attach connecting cables of the external antenna.
- Define the installation location together with the operator.

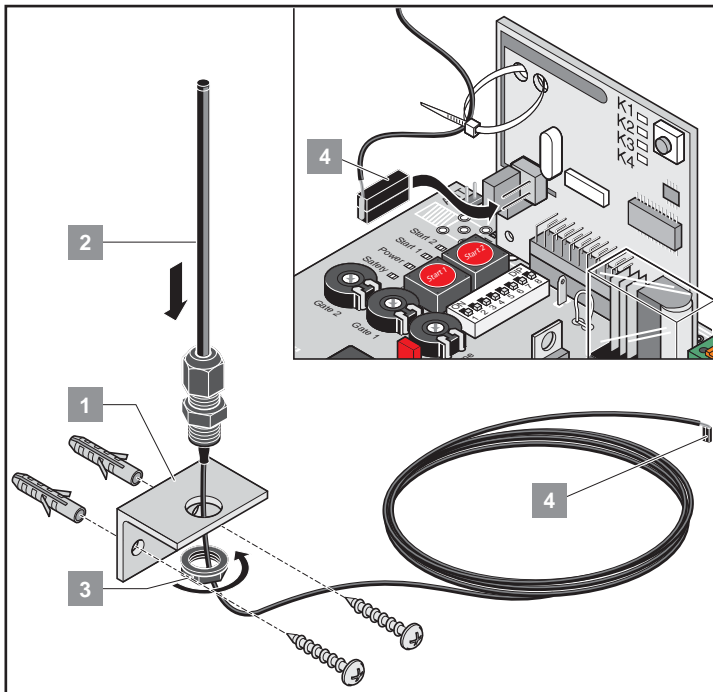
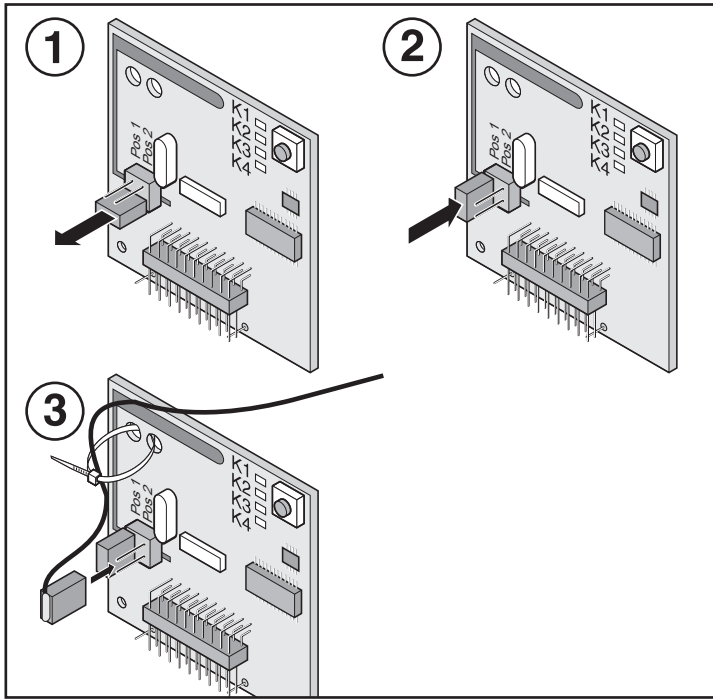



## Safety instructions

- Never operate a damaged operator.
- During opening or closing, no children, people, animals, or objects may be in the range of movement of the gate.
- Do not operate the hand-held transmitter in areas with sensitive radio communications or systems (e.g. airports, hospitals, etc.).
- Actuate the gate system by remote control only if you have a clear view of the gate.
- Keep the hand-held transmitter so that an unintended operation e.g., by children or animals, is prevented.
- Use the radio remote control only if a non-hazardous force tolerance is set. Set the force tolerance low enough to eliminate any danger of injury by the closing force.

## Emergency release in case of power failure

See chapter "Locking and unlocking the operator".

## Normal mode

Changes to the gate affect the force needed for opening and closing.

Examples for changes to the gate:

- Damage
- Moisture absorption
- Ground submergence
- Changes in weather in summer-winter mode
- Obstacles

## Obstacle detection



### IMPORTANT INFORMATION!

**Obstacle detection requires a correctly completed learning run.**

A tolerance for the force required for opening or closing can be set on the potentiometer.

- If the force required increases or decreases within the set tolerance, the control unit automatically learns this value.
- If the force required is outside the set tolerance (e.g. due to an obstacle), the operator stops and reverses a short distance. This power deactivation with reverse is required for safety.

## Summer-winter mode

Differences in weather between summer and winter can influence the operators:

- The force required varies for opening and closing.
- The gate reverses without a noticeable obstacle.
- The end positions of the gate leaf change.

If the gate will not open or close or reverses without a noticeable obstacle:

1. Perform a control unit reset, see chapter "Resetting the control unit".
2. Perform a learning run, see chapter "Performing learning run".

If the end positions have changed:

1. Adjust limit switch.

## Opening and closing gate

### Requirements

- DIP switch 8 to ON.
- Learning run performed.
- Transmitter programmed: Button 1 to channel K1, button 2 on channel K2.

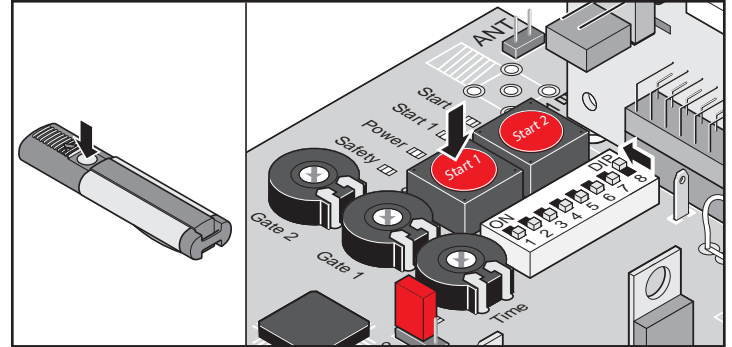

### 1-leaf gate

1. Press button (Start 1) or transmitter button (Button 1).
  - ⇒ Gate opens up to "Gate OPEN" end position – "Limit 1 open" and "Limit 1 close" LEDs light up. "Open" and "Status" LEDs light up.
  - ⇒ Gate opens until "Gate OPEN" end position – "Limit 2 open", "Limit 1 open" and "Limit 1 close" LEDs light up. "Close" and "Status" LEDs go out.

### 2-leaf gate - both gate leaves

1. Press button (Start 1) or transmitter button (Button 1).
  - ⇒ Gate leaf with walk-through gate opens.
  - ⇒ Gate leaf with stop opens with a delay of 3 seconds – "Open" and "Status" LEDs light up.
  - ⇒ "Gate OPEN" end position reached – "Limit 1 open" and "Limit 2 open" LEDs light up. "Close" and "Status" LEDs go out.
2. Press button (Start 1) or transmitter button (Button 1).
  - ⇒ Gate leaf with stop closes.
  - ⇒ Gate leaf with walk-through gate opens with a delay of 5 seconds - "Close" and "Status" LEDs light up.
  - ⇒ "Gate CLOSE" end position reached – "Limit 1 close" and "Limit 2 close" LEDs light up. "Close" and "Status" LEDs go out.

### 2-leaf gate - gate leaf with walk-through gate

1. Press button (Start 2) or transmitter button (button 2).
  - ⇒ Gate opens up to "Gate CLOSE" end position – "Open", "Status" and "Limit 1 close" LEDs light up.
  - ⇒ "Gate CLOSE" end position reached – "Limit 2 open" and "Limit 1 close" LEDs light up. "Close" and "Status" LEDs go out.
2. Press button (Start 2) or transmitter button (button 2).
  - ⇒ Gate closes up to "Gate CLOSE" end position – "Close", "Status" and "Limit 1 close" LEDs light up.
  - ⇒ "Gate CLOSE" end position reached – "Limit 1 close" and "Limit 2 close" LEDs light up. "Close" and "Status" LEDs go out.



# Functions and connections

## Safety instructions

➤ Observe cable requirements:

Property	Value	Terminals
Cross-section	0.25...2.5 mm <sup>2</sup>	All terminals
Maximum length	10 m	5 to 10 35 + 36
Maximum length	30 m	21 to 34

## Jumper

Select 1- or 2-leaf gate.

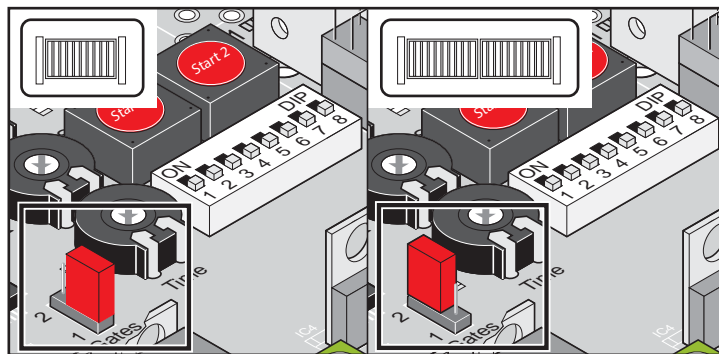

Label	Description
Gates 1/2	1-leaf: Jumper on bottom pins or removed
	2-leaf: Jumper on top pins

## Setting 1- or 2-leaf gate (jumper)

1. Reset the control unit.
2. Replug jumpers.
3. Reset the control unit.
4. Perform learning run.

## Button on control unit

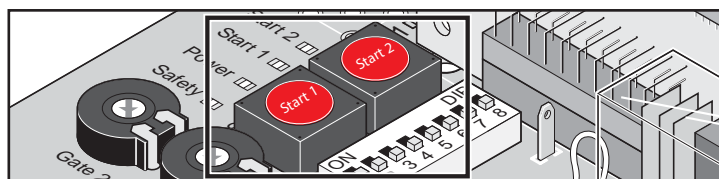

Label	Description
Start 1	Pulse button <ul style="list-style-type: none"> <li>• opens both gate leaves.</li> <li>• Stops moving gate leaf with walk-through gate.</li> <li>• Gate leaf with walk-through gate open: Opens gate leaf with stop.</li> <li>• Function sequence: Open - Stop - Close - Stop - Open ...</li> </ul>
Start 2	Walk-through gate button <ul style="list-style-type: none"> <li>• Opens gate leaf with walk-through gate.</li> <li>• Function sequence: Open - Stop - Close - Stop - Open ...</li> </ul>



### IMPORTANT INFORMATION!

Button (Start 2) operates only if the gate leaf with stop is fully closed.

## Potentiometer for gate leaf length

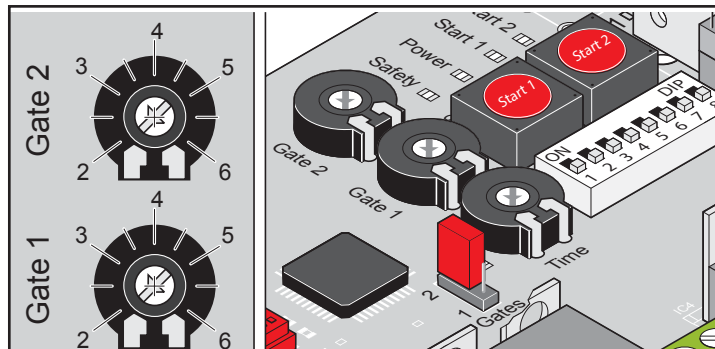

The gate leaf length is set with the "Gate 1" (M1/gate leaf with stop) + "Gate 2" (M2/gate leaf with walk-through gate) potentiometers.

The gate leaf length determines the speed of movement and the force tolerance for the separate leaves.

- Maximum force = learned force + force tolerance

## Radio connector

Slot for radio receiver. Installed on delivery.

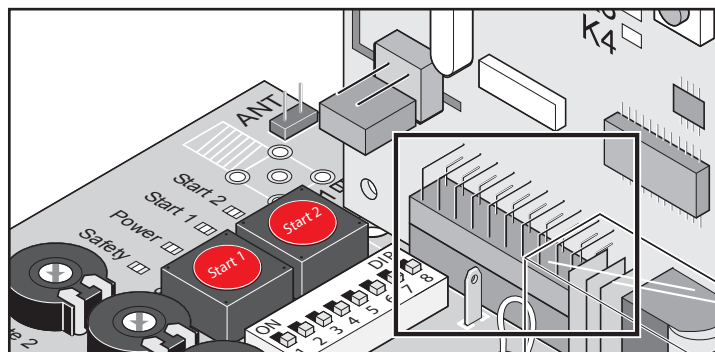

## TorMinal interface

See TorMinal installation and operating manual.

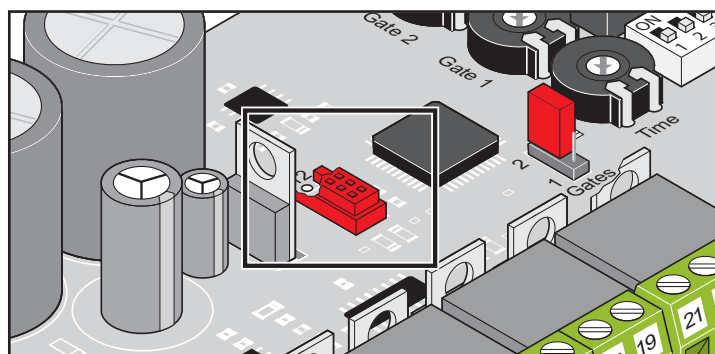

# Functions and connections

## Light-emitting diodes (LED)

Shows the status of the control unit.

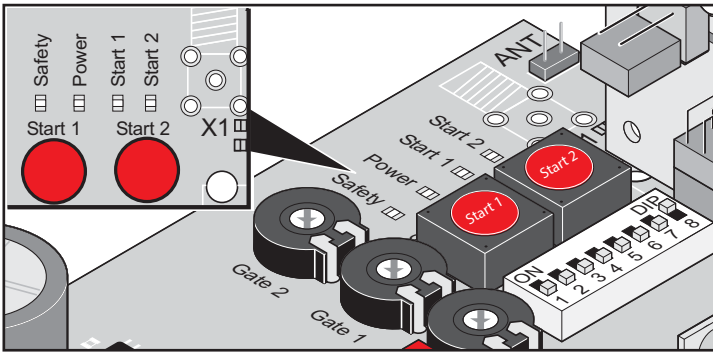

Label	Colour	Status	Description
Safety	Red	Off	Idle mode
		On	Safety input interrupted (e.g. photo eye tripped)



### CAUTION! DANGER OF ELECTROCUTION!

If the fuse is burnt out, the "Power" LED will not be on although the mains voltage (230 V AC) is present on the control unit.

- Before doing any work on the gate or operator, disconnect it from the power supply and lock it to prevent reconnection.

Label	Colour	Status	Description
Power	Green	Off	Power supply interrupted
		On	Mains voltage present
Start 1	Yellow	Off	Idle mode
		On	Start 1 button/radio channel 1 actuated
Start 2	Yellow	Off	Idle mode
		On	Start 2 button/radio channel 2 actuated

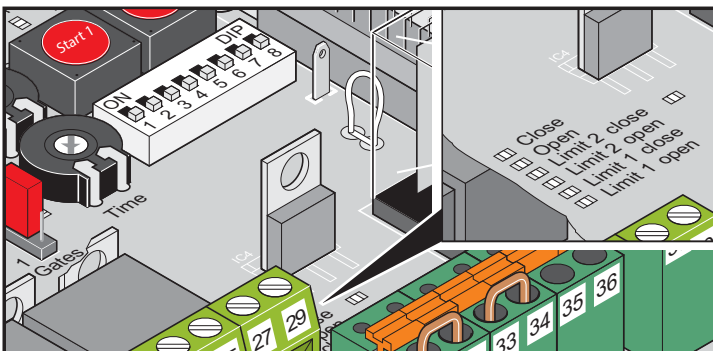

### IMPORTANT INFORMATION!

If both LEDs are on (LED "Limit 2 close" and "Limit 2 open" or "Limit 1 close" and "Limit 1 open"), either no motor is connected or an impermissible operator is connected. See chapter "Mixed operation".

Label	Colour	Status	Description
Close	Yellow	Off	Idle mode
		On	Gate closes
Open	Yellow	Off	Idle mode
		On	Gate opens
Limit 2 close (CLOSE) (M 2)	Red	Off	Idle mode
		On	<ul style="list-style-type: none"> <li>• "Gate CLOSE" limit switch actuated</li> <li>• Impermissible mixed operation</li> <li>• No motor connected</li> </ul>
Limit 2 open (AUF) (M 2)	Red	Off	Idle mode
		On	<ul style="list-style-type: none"> <li>• "Gate OPEN" limit switch actuated</li> <li>• Impermissible mixed operation</li> <li>• No motor connected</li> </ul>
Limit 1 close (M 1)	Red	Off	Idle mode
		On	<ul style="list-style-type: none"> <li>• "Gate CLOSE" limit switch actuated</li> <li>• Impermissible mixed operation</li> <li>• No motor connected</li> </ul>
Limit 1 open (M 1)	Red	Off	Idle mode
		On	<ul style="list-style-type: none"> <li>• "Gate OPEN" limit switch actuated</li> <li>• Impermissible mixed operation</li> <li>• No motor connected</li> </ul>

# Functions and connections

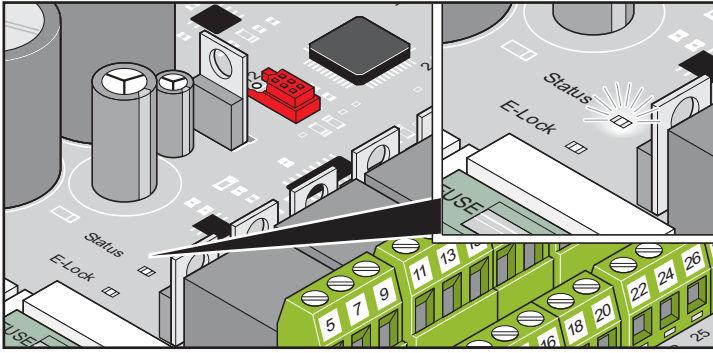

Label	Colour	Status	Description
E-lock	Yellow	Off	Idle mode
		On	E-lock actuated
Status	Yellow	Off	Idle mode with programmed force values
		Flashes	<ul style="list-style-type: none"> <li>• Test mode</li> <li>• Programming (even in dead man mode)</li> <li>• During every gate movement, "Gate OPEN" or "Gate CLOSE".</li> </ul>
		On	<ul style="list-style-type: none"> <li>• Setting only possible with TorMinal.</li> <li>• Behaves as when flashing, warning light also on.</li> </ul>

## DIP switches



### CAUTION!

Before switching the DIP switches, disconnect the power supply to the control unit then secure against switching on again.



### CAUTION!

The gate and its movement zone must always be in sight.

Factory setting for all DIP switches: OFF

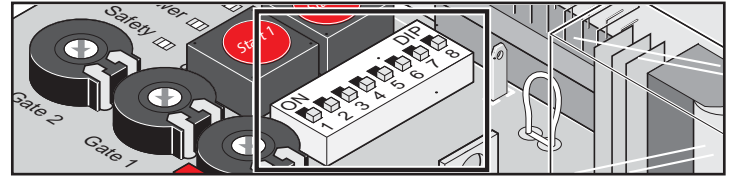

DIP	Function setting "OFF"	Function setting "ON"
1	Response to triggering the safety input (terminals 33 + 34) while the gate opens: <ul style="list-style-type: none"> <li>• No response</li> </ul>	Response to triggering the safety input (terminals 33 + 34) while the gate opens: <ul style="list-style-type: none"> <li>• Gate stops</li> </ul>
2	Safety input setting: <ul style="list-style-type: none"> <li>• 4-wire photo eye normally NC contact</li> </ul>	Safety input setting: <ul style="list-style-type: none"> <li>• 2-wire photo relay</li> </ul>
3	Response to triggering the safety input while the gate closes: <ul style="list-style-type: none"> <li>• Gate reverses</li> </ul>	Response to triggering the safety input while the gate closes: <ul style="list-style-type: none"> <li>• Gate opens completely</li> </ul> Response to triggering the safety input when position DIP 1 = ON: <ul style="list-style-type: none"> <li>• Gate reverses and stops.</li> </ul>
4	Relay contact (terminals 37 + 38) <ul style="list-style-type: none"> <li>• Time relay *</li> </ul>	Relay contact (terminals 37 + 38): <ul style="list-style-type: none"> <li>• gate status display   door status display   door status indicator</li> <li>• * For additional settings, see DIP 6</li> </ul>
5	Pre-warning time warning light: <ul style="list-style-type: none"> <li>• OFF</li> </ul>	Pre-warning time warning light: <ul style="list-style-type: none"> <li>• 3 seconds</li> <li>• Warning light flashes before gate moves</li> </ul>
6	Only if DIP 4 = ON (status display): <ul style="list-style-type: none"> <li>• Gate open – relay contact open</li> <li>• Gate closed – relay contact closed</li> </ul>	Only if DIP 4 = ON (status display): <ul style="list-style-type: none"> <li>• Gate open – relay contact closed</li> <li>• Gate closed – relay contact open</li> </ul>
7	Premature closing (automatic closing): <ul style="list-style-type: none"> <li>• OFF</li> </ul>	Premature closing (automatic closing): <ul style="list-style-type: none"> <li>• ON</li> </ul> Closing delay after actuating the photo eye: <ul style="list-style-type: none"> <li>• 5 seconds</li> </ul> Closing delay without actuating the photo eye: <ul style="list-style-type: none"> <li>• Set stay open time (SOT)</li> </ul>

\* For additional settings see TorMinal owner's manual.

# Functions and connections



## NOTE

After a learning run, leave DIP switch 8 ON. The OFF position immediately deletes all stored values.

DIP	Function setting "OFF"	Function setting "ON"
8	Test mode: <ul style="list-style-type: none"> <li>Operator does not learn any values</li> <li>Setting the limit switches</li> </ul>	Continuous operation: The operator learns continuously while the gate opens and closes: <ul style="list-style-type: none"> <li>Force values</li> <li>Running time</li> <li>Closing delay</li> </ul>

## Automatic closing function

There are two basic variants for automatic closing.

Every basic variant has sub-variants with other settings.

When both variants are activated at the same time, the fully automatic closing function has priority.

## Fully automatic closing function



### IMPORTANT INFORMATION!

When using the automatic close function, ensure compliance with standard EN 12453 (e.g. install photo eye).

- The gate does not close until the set opening time has expired completely.
- Command via button or radio control system during closing:
  - ⇒ The gate completely opens.
- Command via button or radio control system while the SOT expires:
  - ⇒ SOT starts again.
- Continuous signal while the SOT expires:
  - ⇒ The SOT restarts as soon as the continuous signal ends.

## Activating fully automatic operation

- Set SOT (2...120 seconds) on the "Time" potentiometer.



### IMPORTANT INFORMATION!

After every power deactivation, the fully automatic closing function is deactivated.

## Deactivating fully automatic operation

- Turn SOT on the "Time" potentiometer to the left stop.

## Sub-variant 1

- Photo eye interrupted during closing:
  - ⇒ The gate completely opens (independent of DIP 3 position).
  - ⇒ Gate remains open until the photo eye is released.
  - ⇒ The SOT restarts as soon as the photo eye is released.

"Time" potentiometer	Sets the opening time
DIP 7	OFF

## Sub-variant 2

- Photo eye interrupted during opening:
  - ⇒ SOT is 5 seconds.
- Photo eye interrupted in "Gate OPEN" end position:
  - ⇒ SOT is 5 seconds.
- Photo eye interrupted during closing:
  - ⇒ The gate completely opens (independent of DIP 3 position).
  - ⇒ Gate remains open until the photo eye is released.
  - ⇒ SOT is 5 seconds.

"Time" potentiometer	Sets the opening time
DIP 7	ON

## Sub-variant 3

- Photo eye interrupted during opening:
  - ⇒ Gate stops until the photo eye is released.
  - ⇒ The SOT restarts as soon as the photo eye is released.
  - ⇒ DIP 7 position determines the SOT:
    - DIP 7 ON: SOT is 5 seconds.
    - DIP 7 OFF: SOT is the time set on the "Time" potentiometer.
- Photo eye interrupted during closing:
  - ⇒ The gate completely opens (independent of DIP 3 position).
  - ⇒ Gate remains open until the photo eye is released.
  - ⇒ The SOT restarts as soon as the photo eye is released.
  - ⇒ SOT is 5 seconds.

"Time" potentiometer	Sets the opening time
DIP 7	ON (opening time of 5 seconds) OFF (SOT set on the "Time" potentiometer)

# Functions and connections

## Semi-automatic closing function

- Command via button or radio control system while the SOT expires:
  - ⇒ Gate can be closed prematurely.
  - ⇒ SOT starts again.
- Continuous signal while the SOT expires:
  - ⇒ The SOT restarts as soon as the continuous signal ends.
- Photo eye interrupted:
  - ⇒ SOT is 5 seconds.
- "Gate OPEN" end position reached:
  - ⇒ SOT is 60 seconds.
  - Factory setting, can be changed with the TorMinal.

## Activating semi-automatic closing

- Set DIP switch 7 to ON.

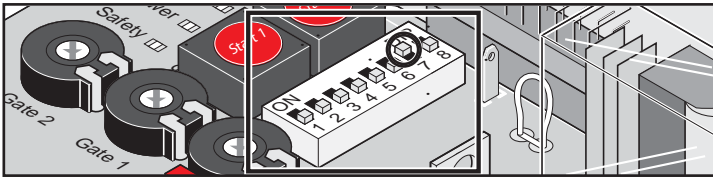

### IMPORTANT INFORMATION!

If an intermediate position is approached in a targeted manner (using the button/radio command), the semi-automatic closing function is deactivated; i.e., after the photo eye is interrupted, the gate is no longer closes automatically.

After the next starting command, the semi-automatic closing function is active again.



### IMPORTANT INFORMATION!

After every power cut-off, the semi-automatic closing function is deactivated.

## Sub-variant 1

- Photo eye interrupted during opening:
  - ⇒ Gate opens until the "Gate OPEN" end position is reached.
  - ⇒ "Gate OPEN" end position reached:
  - ⇒ The SOT restarts as soon as the photo eye is released.
  - ⇒ SOT is 5 seconds.
- Photo eye interrupted during closing:
  - ⇒ The gate completely opens (independent of DIP 3 position).
  - ⇒ Gate remains open until the photo eye is released.
  - ⇒ The SOT restarts as soon as the photo eye is released.
  - ⇒ SOT is 5 seconds.

"Time" potentiometer	Left stop (deactivated)
DIP 7	ON (opening time of 5 seconds)
DIP 1	OFF (no response to the triggering of the safety input with "Gate OPEN")

## Sub-variant 2

- Photo eye interrupted during opening:
  - ⇒ The gate stops.
  - ⇒ The SOT restarts as soon as the photo eye is released.
  - ⇒ SOT is 5 seconds.
  - ⇒ The gate closes on expiration of the SOT.
- Photo eye interrupted during closing:
  - ⇒ The gate completely opens.
  - ⇒ Gate remains open until the photo eye is released.
  - ⇒ The SOT restarts as soon as the photo eye is released.
  - ⇒ SOT is 5 seconds.

"Time" potentiometer	Left stop (deactivated)
DIP 7	ON (opening time of 5 seconds)
DIP 1	ON (response to the triggering of the safety input with "Gate OPEN")

# Functions and connections

## Fuses

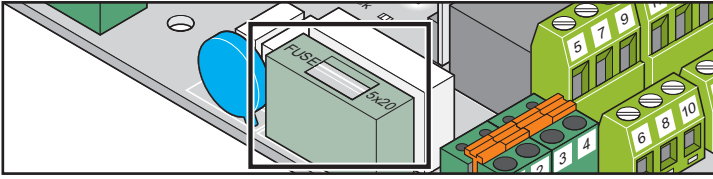

Label	Size	Description
F1	1.6 A, slow-acting	Mains supply line AC 230 V

## Transformer terminal

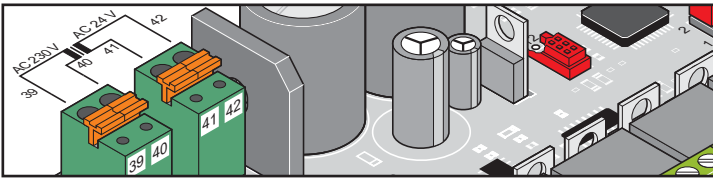

Terminal	Description	Description
39	AC 230 V	Mains supply line (primary winding), brown
40		
41	AC 24 V	Output (secondary winding): Supply line to control unit, white
42		

## DC 24 V electric lock

- Reset control unit before assembly.
- After installation, reset the "Gate CLOSE" end position.
- Uphold the distance between lock and strike: min. 4 mm and max. 6 mm.
- Note the polarity of the electric lock.
- Install lock in a perpendicular position, otherwise it may become jammed during closing or opening.

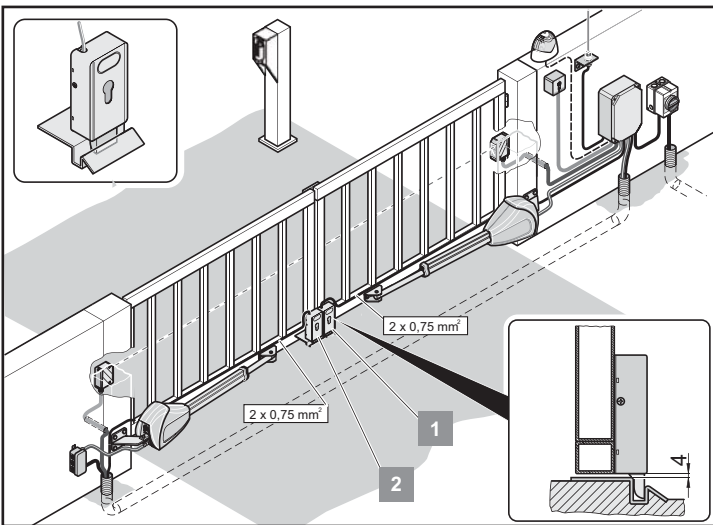

## Connecting electric locks

Available as an accessory.



### IMPORTANT INFORMATION!

The electric lock is operated with direct-current, unregulated transformer voltage. The transformer voltage can fluctuate between DC 22 V ...DC 32 V when fully loaded.

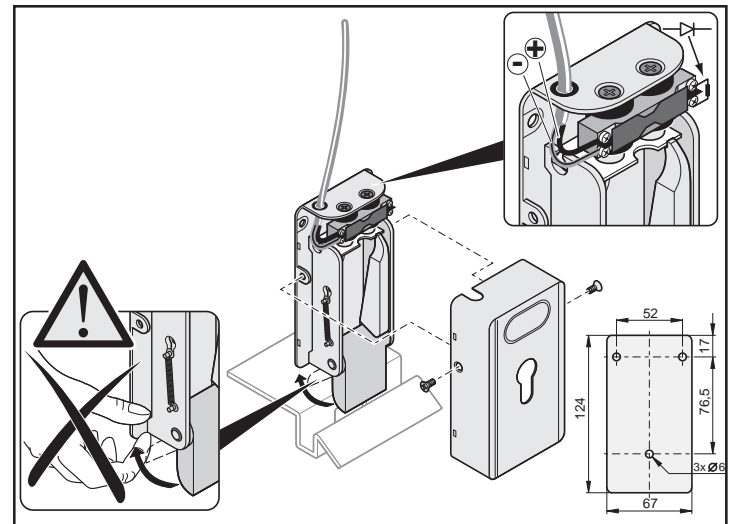
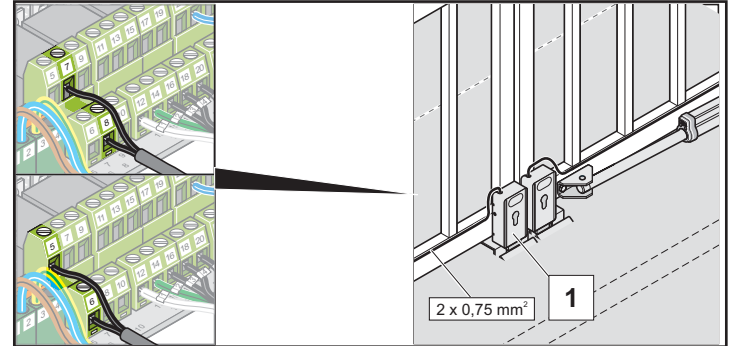

Terminal	Description	Description
5	GND	DC 24 V electric lock connection, limited to 2 A at max. 48 W power.
6	DC 24 V	
7	GND	DC 24 V electric lock connection, limited to 2 A at max. 48 W power.
8	DC 24 V	



# Functions and connections

## Connecting warning light

Available as an accessory.



### IMPORTANT INFORMATION!

The warning light is operated with direct-current, unregulated transformer voltage. The transformer voltage can fluctuate between DC 22 V ...DC 32 V when fully loaded.

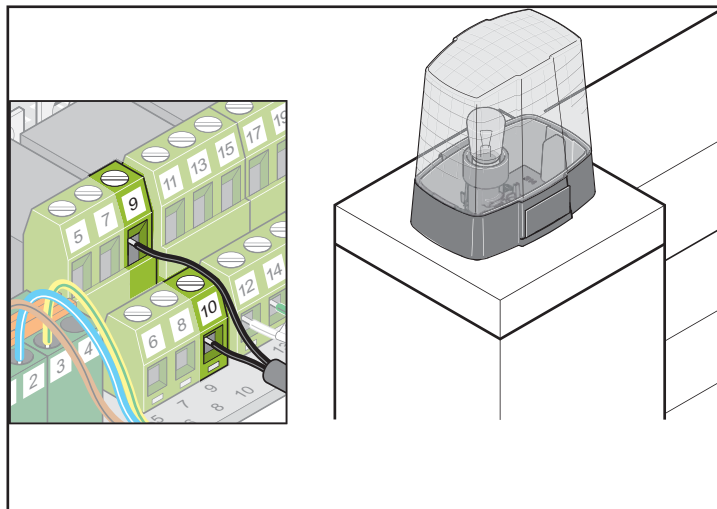

Setting the function, see chapter "DIP switch DIP 5".

Continuous light on is programmable with TorMinal.

Terminal	Description	Description
9	GND	Connection for DC 24 V warning light, limited to 1 A at max. 24 W power.
10	DC 24 V	

## Connecting button

Pulse sequence: OPEN-STOP-CLOSE



### CAUTION!

Only use the connection for potential-free closer contacts. External voltage can trigger severe power surges and damage or destroy the control unit.

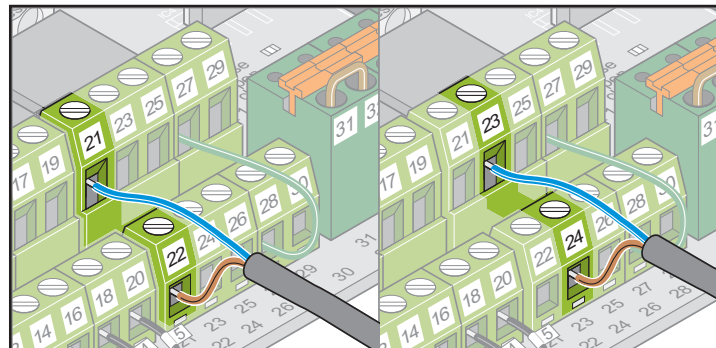

Terminal	Description	Description
21	GND	Connection for pulse transmitter for actuating one or both leaves.
22	Signal	
23	GND	Connection for pulse transmitter for actuating gate wing with walk-through gate.
24	Signal	

- 1-leaf gate: Start 1 and Start 2 buttons have the same function.
- 2-leaf gate: Button 2 contact is needed for the walk-through gate function.

### Button 1 contact

- 1-leaf gate: Buttons at terminals 21 + 22 or 23 + 24
- 2-leaf gate: Buttons at terminals 21 + 22

### 2-contact button

- Gate leaf with walk-through gate terminals 23 + 24
- Both gate leaves 21 + 22



# Functions and connections

## Connecting key switch

**CAUTION!**  
When actuating the key switch the operator must keep clear of the movement zone of gate and must have a direct view of it.

- Never lay the cable of the key switch along a power line to prevent control unit faults.
- Permanently install the switch cable.
- Install key switch at an accessible position.

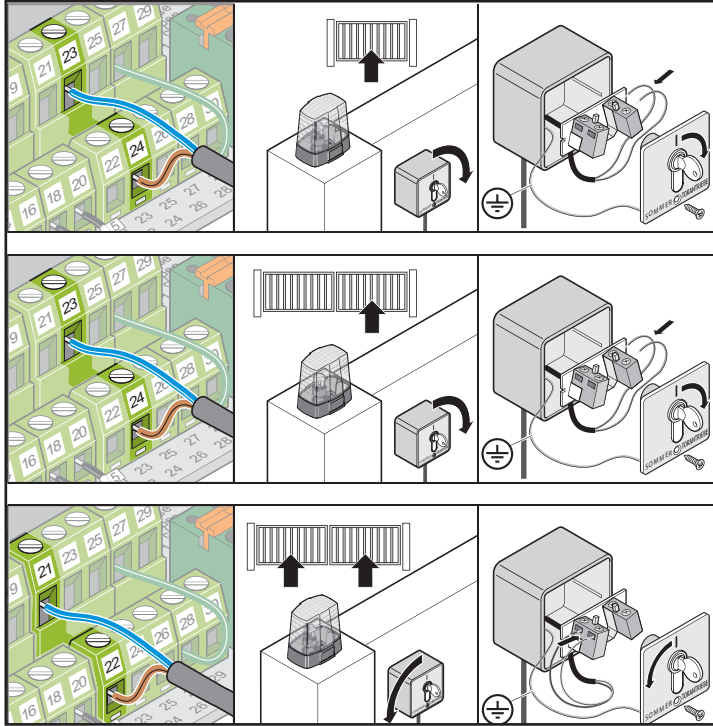

## Connecting button (defined opening)

**CAUTION!**  
Only use the connection for potential-free closer contacts. External voltage can trigger severe power surges and damage or destroy the control unit.

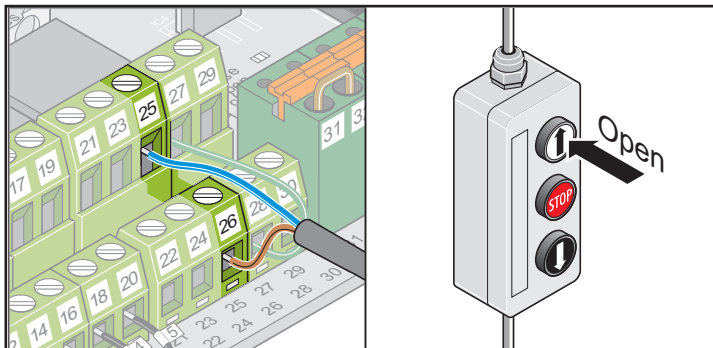

Terminal	Description	Description
25	GND	Connection for pulse transmitter for actuating one or both leaves, "Gate OPEN" only.
26	Signal	

## Connecting button (Gate STOP)

**CAUTION!**  
Only use the connection for potential-free NC contacts. External voltage can trigger severe power surges and damage or destroy the control unit.

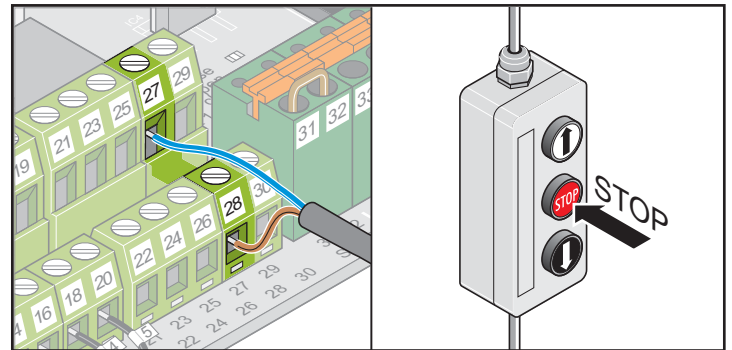

Remove wire bridge before connection.

Terminal	Description	Description
27	-	Connection for pulse transmitter for actuating one or both leaves, "Gate STOP" only.
28	Signal	

## Connecting button (defined closing)

**CAUTION!**  
Only use the connection for potential-free closer contacts. External voltage can trigger severe power surges and damage or destroy the control unit.

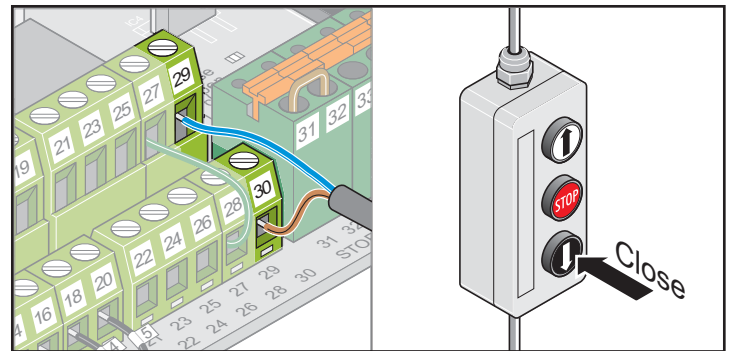

Terminal	Description	Description
29	GND	Connection for pulse transmitter for actuating one or both leaves, "Gate CLOSE" only.
30	Signal	

# Functions and connections

## Connecting EMERGENCY STOP



### CAUTION!

Only use the connection for potential-free NC contacts. External voltage can trigger severe power surges and damage or destroy the control unit.

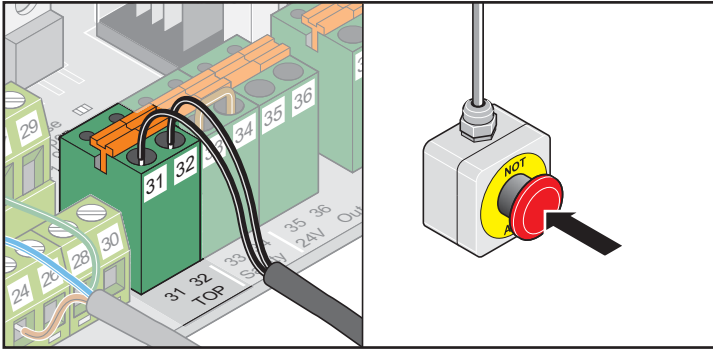

Remove wire bridge before connection.

Terminal	Description	Description
31	-	EMERGENCY STOP interrupts all control unit functions, including dead man operation.
32	Signal	

## Connecting 2-wire photo eye

Available as an accessory.



### CAUTION!

Only use the connection for potential-free NC contacts. External voltage can trigger severe power surges and damage or destroy the control unit.



### IMPORTANT INFORMATION!

When using the automatic closing function, ensure compliance with standard EN 12453 (e.g. install photo eye).

As-delivered status: Jumper between terminals 33 + 34.

Remove wire bridge before connection.

DIP switch 2 "ON".

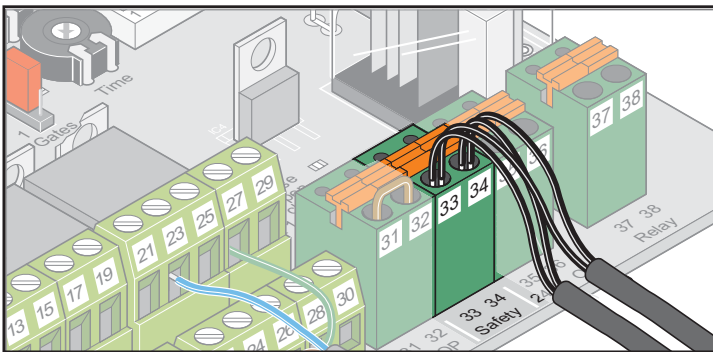

Terminal	Description	Description
33	GND	Connection of 2-wire photo eye (polarity-protected)
34	Signal	If the connection is not used, install a jumper between the terminals (delivery status).

## Connecting 4-wire photo eye

Available as an accessory.



### CAUTION!

Only use the connection for potential-free NC contacts. External voltage can trigger severe power surges and damage or destroy the control unit.



### IMPORTANT INFORMATION!

When using the automatic closing function, ensure compliance with standard EN 12453 (e.g. install photo eye).

As-delivered status: Jumper between terminals 33 + 34.

Remove wire bridge before connection.

DIP switch 2 "OFF".

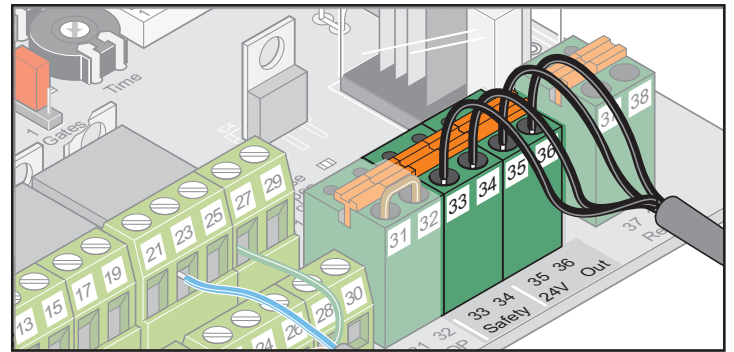

Terminal	Description	Description
33	GND	Safety device connection, e.g. <ul style="list-style-type: none"> <li>Photo eye</li> </ul>
34	Signal	<ul style="list-style-type: none"> <li>Safety contact strip requires separate evaluation unit.</li> </ul> Contact must be closed when the safety device is in non-actuated state. If the connection is not used, install a jumper between the terminals (delivery status).
35	DC 24 V max. 100 mA	DC 24 V output, max. 100 mA Photo eye power supply for transmitter and receiver.
36	GND	

## Connecting external consumers

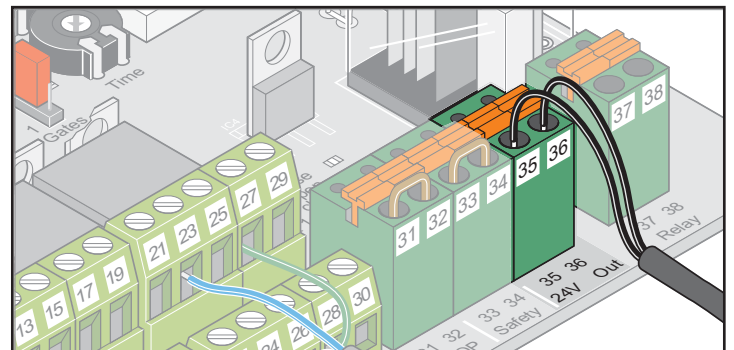

Terminal	Description	Description
35	DC 24 V max. 100 mA	DC 24 V output, max. 100 mA
36	GND	

# Functions and connections

## Connecting potential-free relay contact

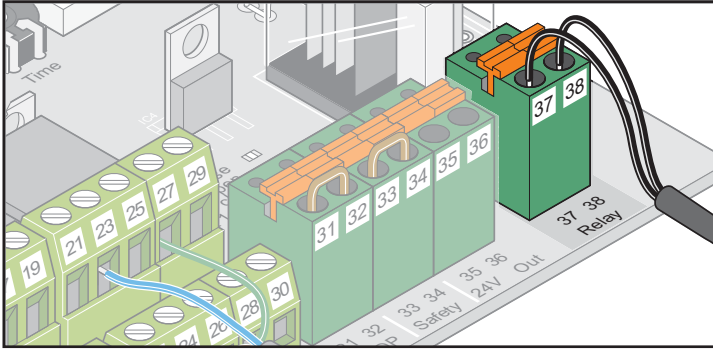

Terminal	Description	Description
37	Potential-free relay contact	Connection for e.g. light max 8 A, 230 V resistance load
38		

## Connecting motor

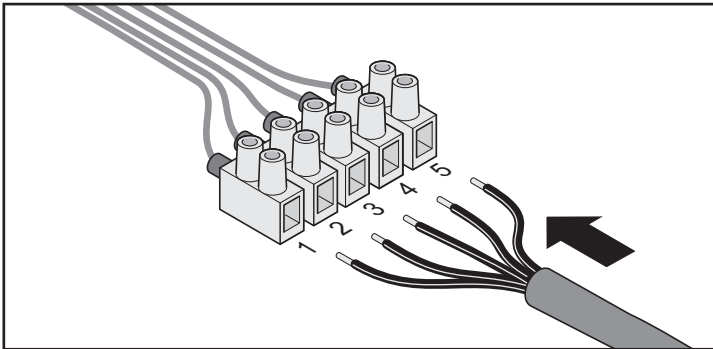

Cable number	Cable colour	Description
1	White	Motor
2	Green	Motor
3	Blue	"Gate CLOSE" limit switch
4	Yellow	"Gate OPEN" limit switch
5	Blue + yellow	Earth "Gate OPEN" + and "Gate CLOSE" limit switch

## Attaching connecting cable set

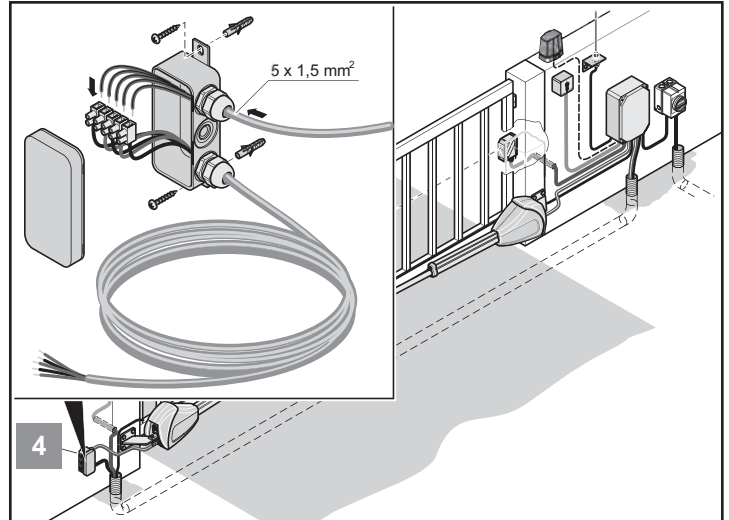

1. Fasten terminal box with screws through the eyelets.
2. Connect cable with the same number:
  - 1 : 1
  - 2 : 2
  - etc.
3. Tighten PG fasteners well to prevent ingress of moisture into the terminal box.
4. Close terminal box.

## Main switch

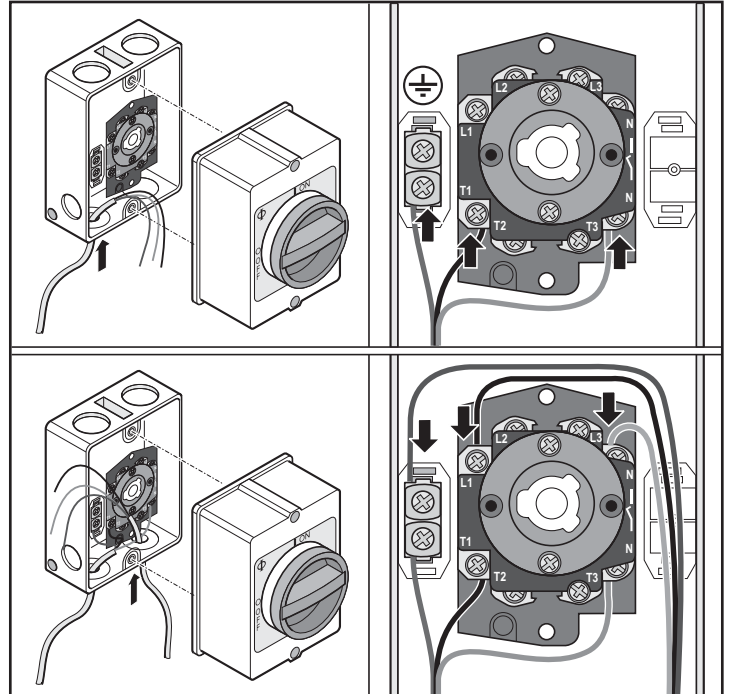

# Maintenance and care

## Safety instructions



### DANGER!

Never use a water hose or high-pressure cleaner to spray down the operator or the control unit housing.

- Do not use acids or alkalis for cleaning.
- Keep operator clean and clean the push rod with a dry cloth when needed.
- Check the control unit housing regularly for insect infestation and clean if necessary.
- Check the control unit housing regularly for moisture and dry if necessary.
- Check that all screws and bolts of the fittings are tightened. Retighten loose fixing bolts.
- Check that the connection control unit housing cover is free of leaks.

## Regular testing

- Check the function of the safety devices at least every 6 months. See EN 12453:2000.
- Check the function of the pressure-sensitive safety devices at least every 4 weeks. Example: Safety contact strip with separate evaluation unit. See EN 60335-2-95:11-2005.

Testing	Behaviour	Yes or No	Possible cause	Remedy
<b>Power deactivation</b> Stop the gate leaf by hand while it is closing. Do not clutch the gate leaf.	Does the gate stop and reverse when lightly held?	Yes		No action necessary.
		No	Force tolerance too high.  Control unit defective.	Reducing force tolerance: <ul style="list-style-type: none"> <li>• Open and close the gate completely twice under supervision.</li> <li>• Rotate the "Gate 1" or "Gate 2" potentiometer completely to the left until the test is successful.</li> </ul> • Decommission the gate and lock it to prevent reactivation. • Call customer service!
<b>Emergency release</b> Procedure as described under "Locking and unlocking operator".	Can the gate be opened and closed easily by hand? Can the operator be unlocked?	Yes		No action necessary.
		No	Hinges rusted.	Lubricate gate hinges.
<b>Safety contact strip, if present.</b> Open/close the gate and actuate the strip.	Does the gate behave as set with DIP switch 1, 2 or 3?	Yes		No action necessary.
		No	Cable broken.	<ul style="list-style-type: none"> <li>• Check wiring.</li> <li>• Replace broken cables.</li> </ul>
		Terminal loose.	Tighten terminal.	
		DIP switch adjusted.	Set the DIP switch.	
<b>Photo eye, if present</b> Open/close the gate and interrupt photo eye.	Does the gate behave as set with DIP switch 1, 2 or 3? "Safety" LED on?	Yes		No action necessary.
		No	Cable broken.	<ul style="list-style-type: none"> <li>• Check wiring.</li> <li>• Replace broken cables.</li> </ul>
		Terminal loose.	Tighten terminals.	
		DIP switch adjusted.	Set the DIP switch.	
		Photo eye soiled.	Clean the photo eye.	
Photo eye fault.	<ul style="list-style-type: none"> <li>• Decommission the gate and lock it to prevent reactivation.</li> <li>• Call customer service!</li> </ul>			

## Disassembly



### IMPORTANT!

Observe the safety notices!

See "Safety instructions", page 3.

The sequence is identical to that described in the "Mounting" section, but in reverse order. Ignore the setting instructions.

## Disposal

Observe applicable national regulations.

## Warranty and customer service

The warranty complies with statutory requirements.

Please contact your specialist retailer/supplier if you have any queries regarding the warranty.

The warranty is only valid in the country in which the product was purchased.

Batteries, fuses and bulbs are excluded from the warranty.

Ownership of replaced parts passes to us.

If you require after-sales service, spare parts or accessories, please contact your specialist retailer/supplier.

We have tried to make the installation and operating manual as easy as possible to follow. If you have any suggestions as to how we could improve it or if you think more information is needed, please send your suggestions to us:

Fax: +49 (0) 7021/8001-403

E-mail: [doku@sommer.eu](mailto:doku@sommer.eu)

# Troubleshooting

## Tips on troubleshooting

Fault	Control	Yes or No	Possible cause	Remedy
Gate cannot be opened or closed with buttons or hand-held transmitter.	"Power" LED on?	No	No supply voltage.	<ul style="list-style-type: none"> <li>• Check connection.</li> <li>• Establish missing connection.</li> </ul>
			Fuse defective.	<ul style="list-style-type: none"> <li>• Check fuse.</li> <li>• Replace defective fuse.</li> </ul>
		Yes	Gate jammed. Gate leaf has sunk or distorted because of high temperature variations.	Fix misaligned gate leaves.
			Motor hums but does not move.	<ul style="list-style-type: none"> <li>• Switch off immediately! Possible motor or control unit fault.</li> <li>• Contact customer service.</li> </ul>
			Operator unlocked.	Lock operator.
			Cable does not have a contact.	Check the cable connection.
			Gate frozen.	Clear snow and ice from gate and hinges.
Snow is blocking the movement zone of gate.	Clear snow.			
Is the LED on the transmitter on?	No	Battery flat.	Replace battery.	
		Battery incorrectly inserted.	Insert battery correctly.	
		Hand-held transmitter defective.	Replace the hand-held transmitter.	
	Yes	Range of the transmitter too short due to weak battery.	Replace battery.	
		Radio receiver defective.	Replace radio receiver.	
		Hand-held transmitter not programmed.	Program transmitter.	
		Poor reception.	Install external antenna, see chapter "Accessories".	
Incorrect frequency.	<ul style="list-style-type: none"> <li>• Check frequency.</li> <li>• Check that transmitter and radio receiver are on the same frequency.</li> </ul>			
	Does an LED on the radio receiver come on if a button on the transmitter is pressed?	No	Radio receiver not properly plugged in.	Plug in radio receiver properly.
			Radio receiver defective.	Replace radio receiver.
			Radio receiver without power supply.	Replace radio receiver.
Transmitter not programmed.			Program transmitter.	
Is the "POWER + OPEN/ CLOSE" LED on?	Yes	Continuous signal pending. Pulse generator defective.	<ul style="list-style-type: none"> <li>• Check pulse generator.</li> <li>• Replace defective pulse generator.</li> </ul>	
"POWER + Safety" LED on?	Yes	Photo eye interrupted. *	Remove interruption.	
Does the fault occur intermittently or for a short time?	Yes	Very powerful public address systems in hospitals or industrial areas may interfere with the radio control system.	<ul style="list-style-type: none"> <li>• Change radio frequency.</li> <li>• Contact source of interference.</li> </ul>	
Does "Safety" LED flash quickly?	Yes	The control unit has stored faulty values (e.g. due to a short power failure).	<ul style="list-style-type: none"> <li>• Reset the control unit.</li> <li>• Reprogram the operator.</li> <li>• If not possible, call customer service.</li> </ul>	



# Troubleshooting

Fault	Control	Yes or No	Possible cause	Remedy
Gate cannot be opened or closed with a connected key switch.	"POWER + Start 1/Start 2" LEDs on?	Yes	Cable connections interrupted?	Tighten terminal.
			Key switch defective.	Replace key switch.
		No	Permanent contact due to damaged wire insulation.	<ul style="list-style-type: none"> <li>Check wiring.</li> <li>Replace damaged cables.</li> </ul>
Gate remains stationary and reverses during opening and closing.	Is there an obstacle outside the range of motion?	No	Hinges stiff.	Lubricate hinges.
			Post or pillar has changed.	Align posts/pillars.
			Limit switch out of adjustment.	Adjust limit switch.
	Yes	Power cut-off tripped.	Remove obstacle.	
	Does the gate leaf vibrate when moving?	Yes	Gate leaf unstable.	Reinforce gate leaf.
Strong wind load?	Yes	Wind pressure too strong.	Open and close gate again.	
Gate remains stopped when opening.	Photo eye interrupted?	Yes	Obstacle in light beam.	Remove obstacle.
			Photo eye soiled.	Clean the photo eye.
Gate does not open or close completely.	Does the gate stop before the set end position?	No	Gate fittings not installed correctly.	Change the gate bracket.
		Yes	Limit switch incorrectly adjusted.	Adjust limit switch.
Closing sequence incorrect.			Operators incorrectly connected.	Connect operators as specified in the manual.
Operator does not learn the force values.			DIP switch 8 to OFF.	Set DIP switch 8 to ON.
Gate does not stop at an obstacle.			Gate in learning mode. DIP switch 8 to ON. Force tolerance too high.	<ul style="list-style-type: none"> <li>After learning mode the power cut-off responds.</li> <li>Set DIP switch 8 to OFF.</li> <li>Reduce force tolerance.</li> </ul>
Operator stops at pillar.	Are the A/B dimensions correct?	No	A or B dimension not correct.	Adjust fastening of operator to post or pillar.
		Yes	Limit switch out of adjustment.	Adjust limit switch.
Gate moves unevenly.			A/B dimensions unequal.	Change installation dimension.
Walk-through gate does not open with transmitter.			Hand-held button not programmed.	Program button.
Operators do not start.	Does "Safety" LED flash quickly?	Yes	Jumper was moved with programmed force values.	<ul style="list-style-type: none"> <li>Place jumper in previous position.</li> <li>Reset the control unit.</li> <li>Replug jumpers.</li> <li>Perform learning runs.</li> </ul>

\* If photo eye is uninterrupted, the operator can be moved in dead man mode with the "Open" and "Close" buttons. If an obstacle is detected, power deactivation also occurs in this operating mode.

## Additional support during troubleshooting

When the troubleshooting tips are not successful, take the following measures:

- Reset the control units (delete force values).
- Disconnect the connected accessories (e.g. photo eye) and use wire bridges again.
- Set all DIP switches to the factory setting.
- Turn potentiometer to the factory setting.
- If settings have been changed using TorMinal, perform the control unit reset with TorMinal.

Dealers offer additional support during troubleshooting and elimination of faults.



# Connection diagram

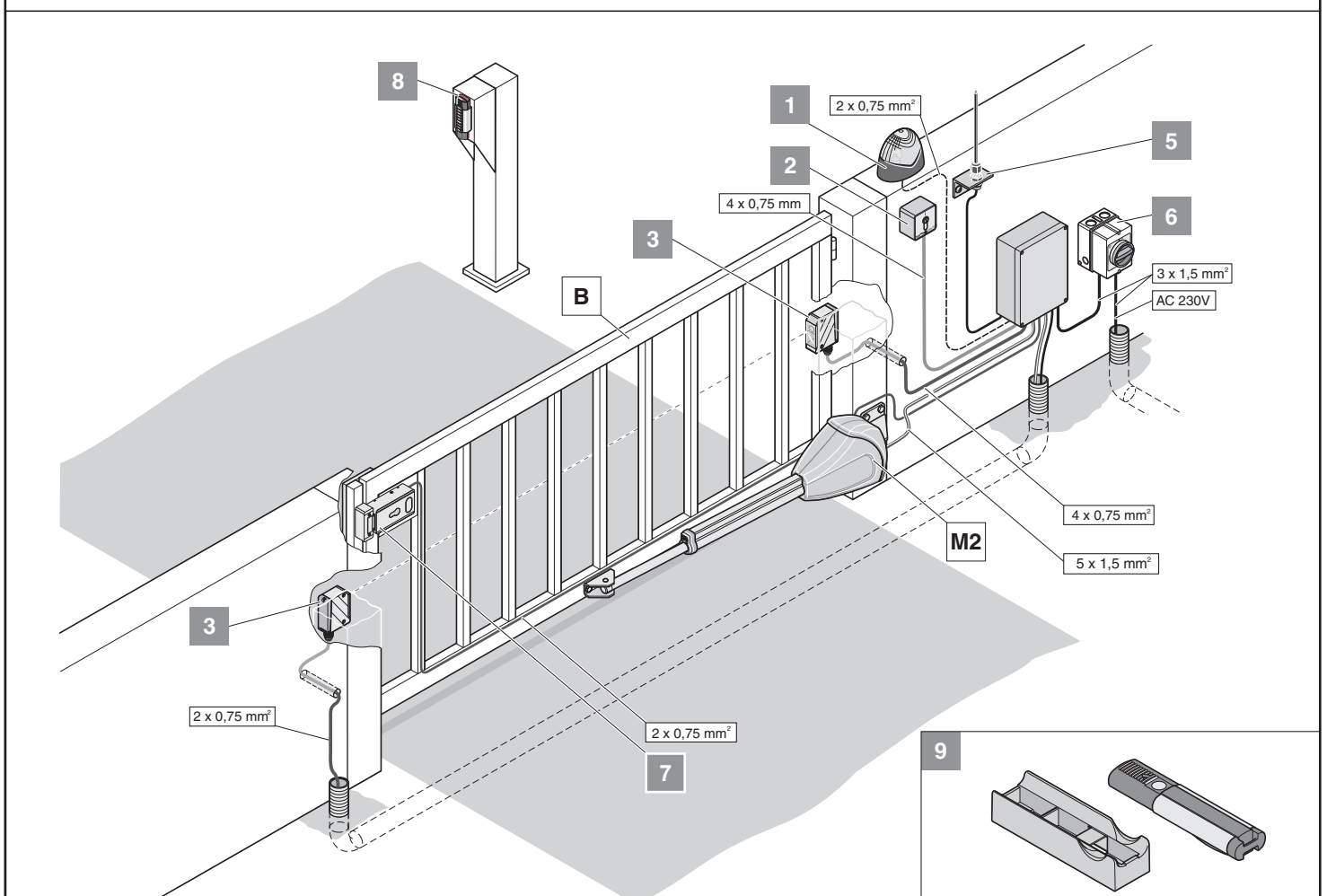
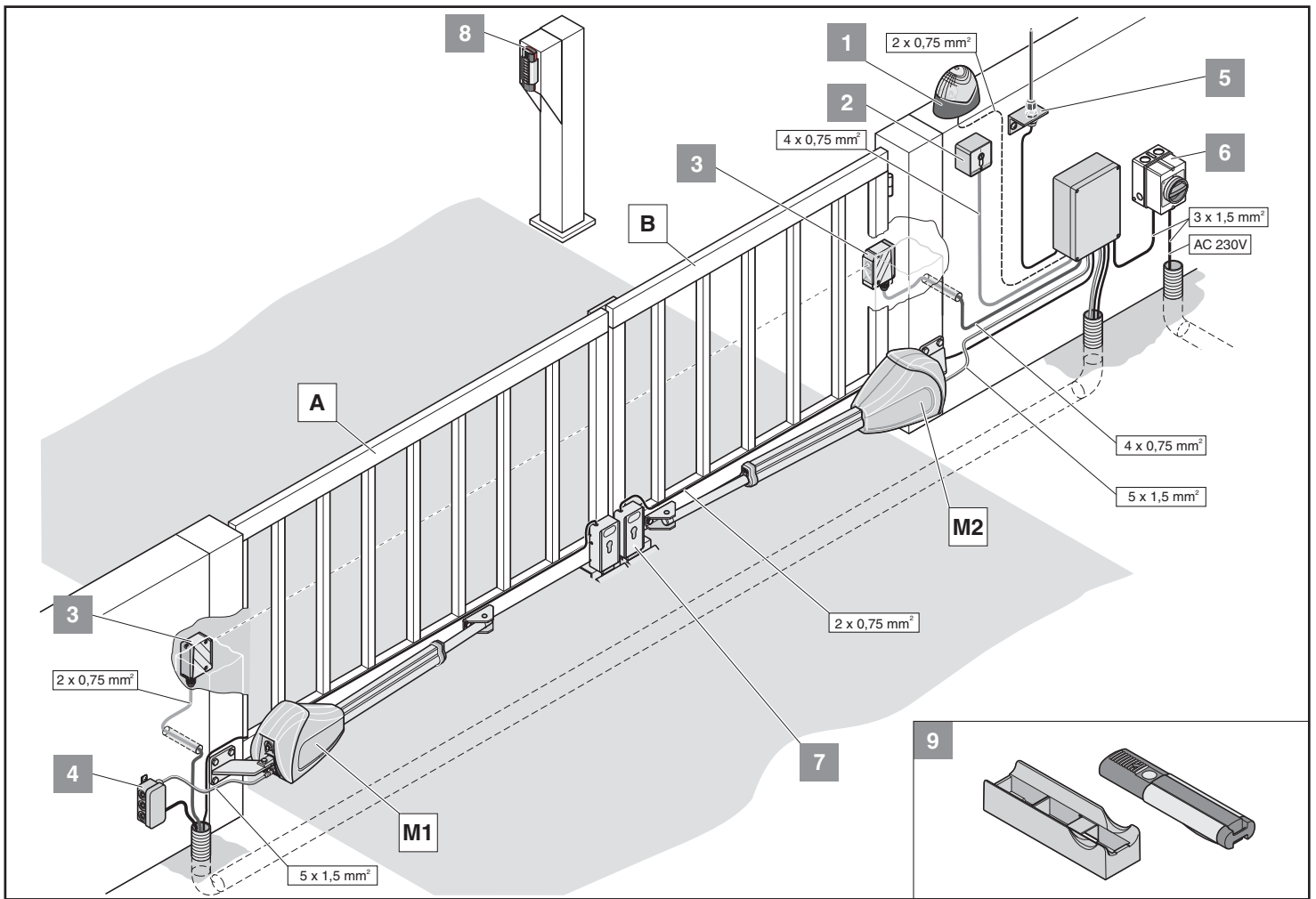

# DTA-1 control unit

## DIP switch settings

Switch	Function in "OFF" setting	Function in "ON" setting	Comments
1	Response to triggering the safety input (terminals 33 + 34) while the gate opens: <ul style="list-style-type: none"> <li>No response</li> </ul>	Response to triggering the safety input while the gate opens: <ul style="list-style-type: none"> <li>Gate stops</li> </ul>	Terminals 33 + 34
2	Safety input setting: <ul style="list-style-type: none"> <li>4-wire photo eye normally NC contact</li> </ul>	Safety input setting: <ul style="list-style-type: none"> <li>2-wire photo eye</li> </ul>	Terminals 33 + 34
3	Response to triggering the safety input while the gate closes: <ul style="list-style-type: none"> <li>Gate reverses</li> </ul>	Response to triggering the safety input while the gate closes: <ul style="list-style-type: none"> <li>Gate opens completely</li> </ul> Response to triggering the safety input when position DIP 1 = ON: <ul style="list-style-type: none"> <li>Gate reverses and stops.</li> </ul>	Terminals 33 + 34
4	Relay contact: <ul style="list-style-type: none"> <li>Time relay</li> </ul>	Relay contact: <ul style="list-style-type: none"> <li>gate status display   door status display   door status indicator</li> <li>* For additional settings, see DIP 6</li> </ul>	<ul style="list-style-type: none"> <li>Terminals 37 + 38</li> <li>TorMinal Mem 022</li> </ul>
5	Pre-warning time warning light: <ul style="list-style-type: none"> <li>OFF</li> </ul>	Pre-warning time warning light: <ul style="list-style-type: none"> <li>3 seconds</li> <li>Warning light flashes before gate moves</li> </ul>	TorMinal Mem 016
6	Only if DIP 4 = ON (status display): <ul style="list-style-type: none"> <li>Gate open - relay contact open</li> <li>Gate closed - relay contact closed</li> </ul>	Only if DIP 4 = ON (status display): <ul style="list-style-type: none"> <li>Gate open - relay contact closed</li> <li>Gate closed - relay contact open</li> </ul>	Terminals 37 + 38
7	Premature closing (during automatic closing): <ul style="list-style-type: none"> <li>OFF</li> </ul>	Premature closing (during automatic closing): <ul style="list-style-type: none"> <li>ON</li> </ul> Closing delay after actuating the photo eye, e.g. after drive-throughs: <ul style="list-style-type: none"> <li>5 seconds</li> </ul> Closing delay without actuating the photo eye: <ul style="list-style-type: none"> <li>Set stay open time (SOT)</li> </ul>	TorMinal Mem 021
8	Test mode: <ul style="list-style-type: none"> <li>Operator does not learn any values</li> <li>Setting the limit switches</li> </ul>	Continuous operation: <p>The operator learns continuously while the gate opens and closes:</p> <ul style="list-style-type: none"> <li>Force values</li> <li>Running time</li> <li>Closing delay</li> </ul>	Leave DIP switch 8 in ON position after programming.

## TorMinal settings

Storage location	Setting range	Value	Functional description
Mem	Val	Increment Val	
014	0 ...15	0 ...7	Warning light, dead man operation, power deactivation 2 Example: Warning light is to flash (1) + power deactivation 2 (4): 1 + 4 = 5, enter 5 and save this value.
		0	Warning light lights up during a gate movement
		1	Warning light flashes during a gate movement
		2	Dead man operation
		4	Switch power deactivation (1 -> 2): More sensitive activation for smaller B dimensions and smooth-running gates.
016	8 ...40	0.25 s	Pre-warning time Early warning time period Example: Displayed value 40 = 10 seconds
021	1 ...20	1 s	Closing time photo eye Duration of the stay open time, after driving through the photo eye, only in conjunction with automatic closing function.
022	1 ...255	1 s	Switching duration relay contact Duration that the relay contact is closed after motor start.
042	0 ...8	0.25 s	Motor 2: Close trailing gate After reaching the gate CLOSE end position, the operator continues to run in order to close the gate cleanly (gate leaves are braced with each other by this).

# Wiring diagram

twist 350 / twist XL

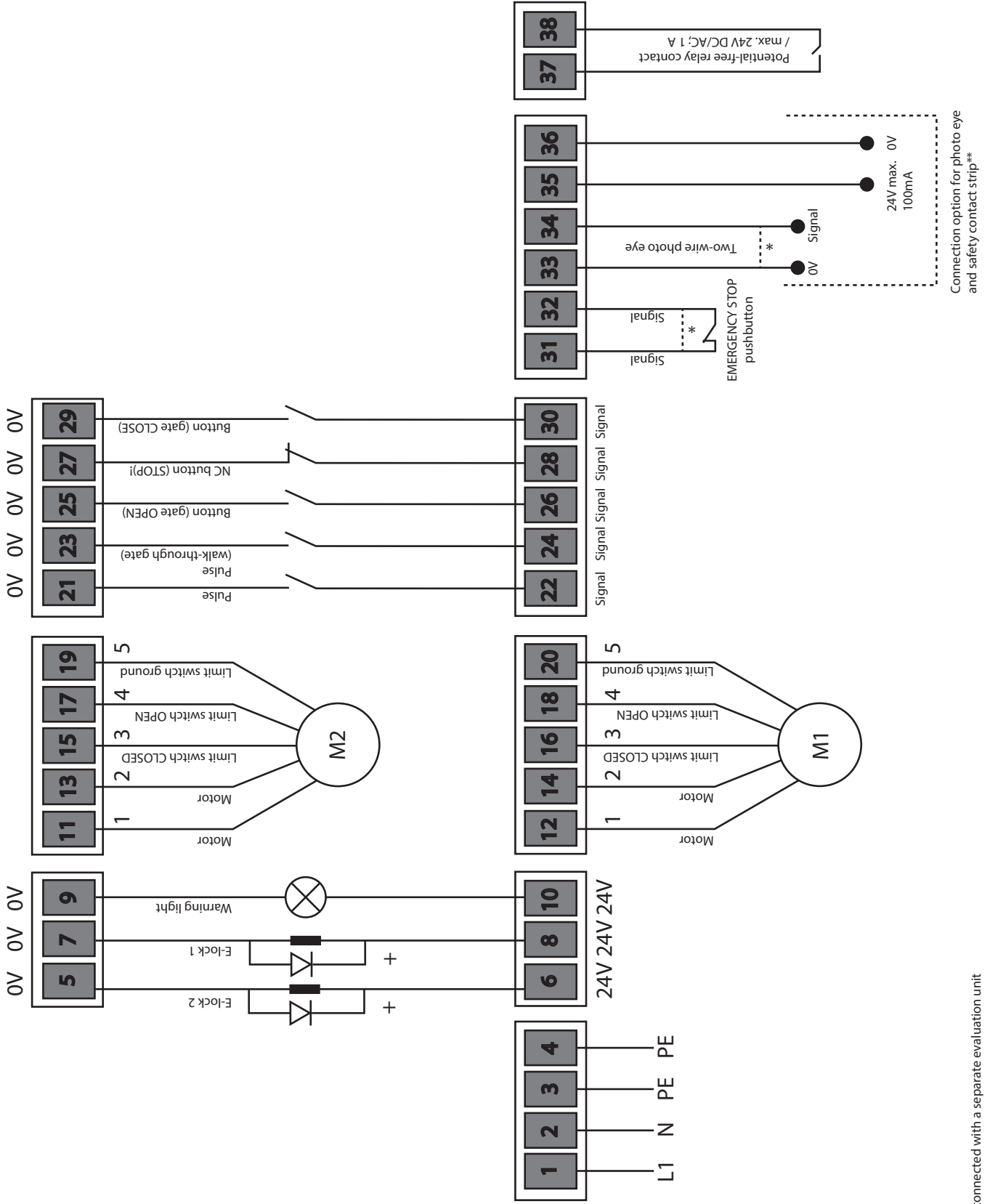

\*delivery status with wire jumper

\*\*Safety contact strip can only be connected with a separate evaluation unit

**SOMMER Germany**

SOMMER Antriebs- und Funktechnik GmbH

Hans-Böckler-Strasse 21-27  
73230 Kirchheim/Teck,  
Germany

Telephone: +49 7021 8001-0  
Fax: +49 7021 8001-100

[info@sommer.eu](mailto:info@sommer.eu)  
[www.sommer.eu](http://www.sommer.eu)

© Copyright 2017 All rights reserved